

SPARTAK ENTERPRISES, INC.



KITCHEN ISLAND

Model #4124-11WH

LOT #

IF PARTS ARE MISSING AND OR DEFECTIVE, IF INSTRUCTIONS ARE NOT CLEAR
OR IF YOU ARE EXPERIENCING PROBLEMS ASSEMBLING OUR PRODUCT.







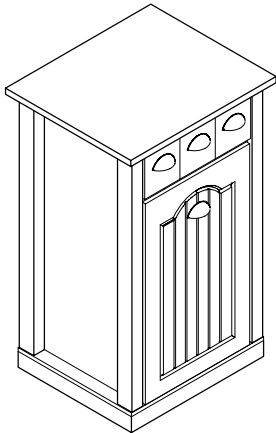

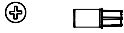

**BEFORE YOU RETURN THE PRODUCT TO THE STORE,
PLEASE CALL US TOLL FREE FOR CUSTOMER SERVICE ASSISTANCE
(888) 777-8250**

**OR SEND US EMAIL AT
help@spartakent.com**

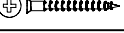
PLEASE HAVE MODEL AND W/O NUMBER READY, AND A REPRESENTATIVE WILL GLADLY
ASSIST YOU

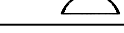
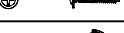
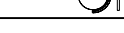
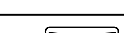
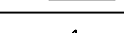

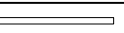
HARDWARE LIST

HARDWARE	PART NUMBER	DESCRIPTION	QTY
	WRPBL	WHEEL RUNNER	2
	CAMLT12	CAMLOCK	8
	CAMBT12	BOLT	8
	DOWW525	WOOD DOWEL	44
	SF612BL	FLAT HEAD SCREW	30
	SFH845A	WOOD SCREW	4
	DOWW830	WOOD DOWEL	8
	PUSHWOSN	SHELL METAL PULL	4
	SRM415Z	MACHINE SCREW	8
	CAS50	CASTER W/FLAT PLATE	4
	HIN356S	HINGE	1
	TOWPLWH	PAPER TOWEL HOLDER	1
	SF812Z	PAN HEAD SCREW	2
	GLUEWD	GLUE	1
	SCF50PZB	CONFIRMAT SCREW	4
	DOWW14X48	ROD	3

PARTS IDENTIFICATION

NOTE: FIRST MAKE SURE THAT YOU HAVE ALL OF THE PARTS LISTED ON THIS SHEET. IF YOU ARE MISSING ANY PIECE(S), DO NOT ASSEMBLE THE UNIT. INSTEAD, CALL OUR CUSTOMER SERVICE NUMBER AT: (888) 777-8250. WE WILL BE HAPPY TO ASSIST YOU.

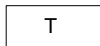
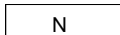
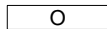
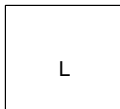
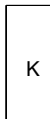
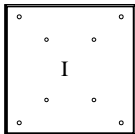
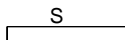
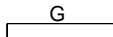
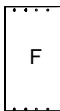
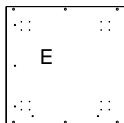
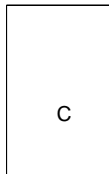
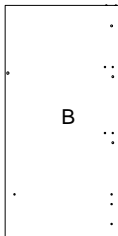
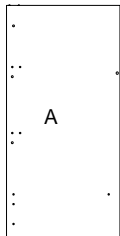

4124A-Left End Panel	1pc
4124B-Right End Panel	1pc
4124C-Divider	1pc
4120D-Waste Bin Holder Side	2pcs
4124E-Base	1pc
4120F-Waste Bin Holder Back	1pc
4124G-Bottom Skirt	2pcs
4124H-Door	1pc
4124I-Top	1pc
4121K-Divider	2pcs

4124L-Fixed Shelf	1pc
4120M-Bottom	1pc
4124N-Fixed Shelf	2pcs
4124O-Drw Bottom	3pcs
4124R-Drw Back	3pcs
4124P-Drw Mt Fold	3pcs
4124S-Bottom Skirt	2pcs
4121T- Back	1pc

SDUWV #DUH #X VXD00 \ #P DUNHG #R Q #WKH #UDZ #HGJH1

1

We recommend you do one drawer at the time.

The excess of glue can be wiped off with a damp cloth. Also, once glue sets it will turn translucent and it will not stick to laminated surface and can be easily peeled off.

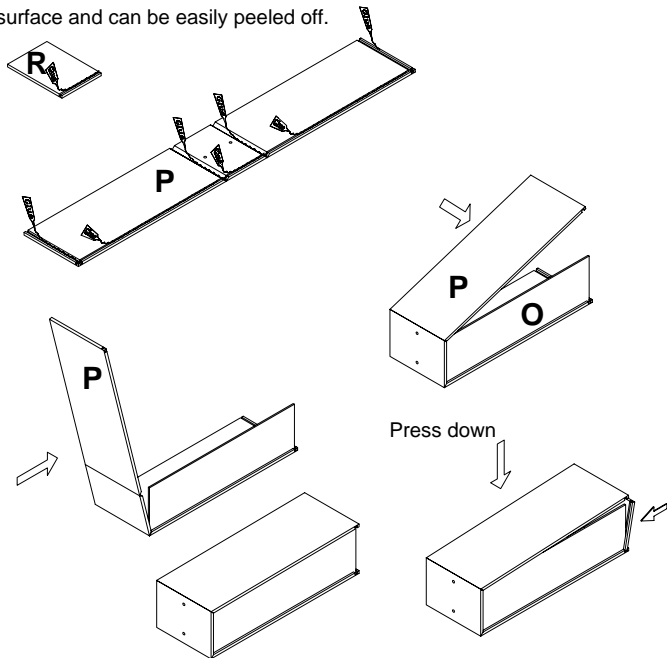

Allow glue to set at least for 2 hours. Repeat this step for the other two drawers. Make sure drawer back fits snug and there are no gaps. Leave drawers on their side until glue has set. You may put weight on it, like couple of books to apply pressure. In the mean time you can complete assembly of the frame of the island.

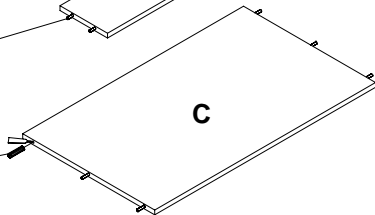
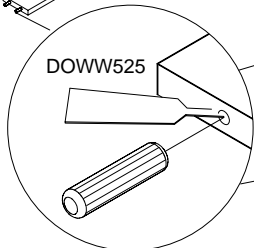
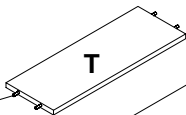
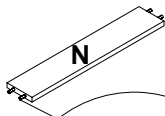
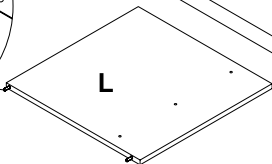
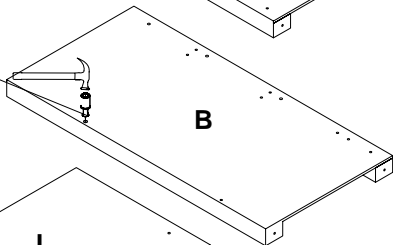
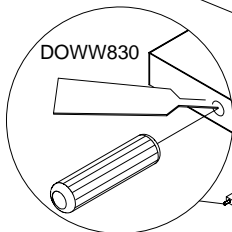
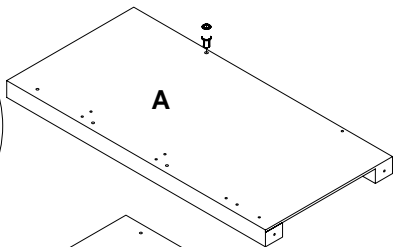
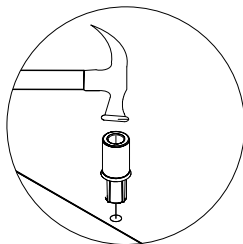
2

Apply one drop of glue in each hole with the wood dowels. Make sure the dowels go in as far as possible, they should stick out no more than $\frac{3}{8}$ of an inch.

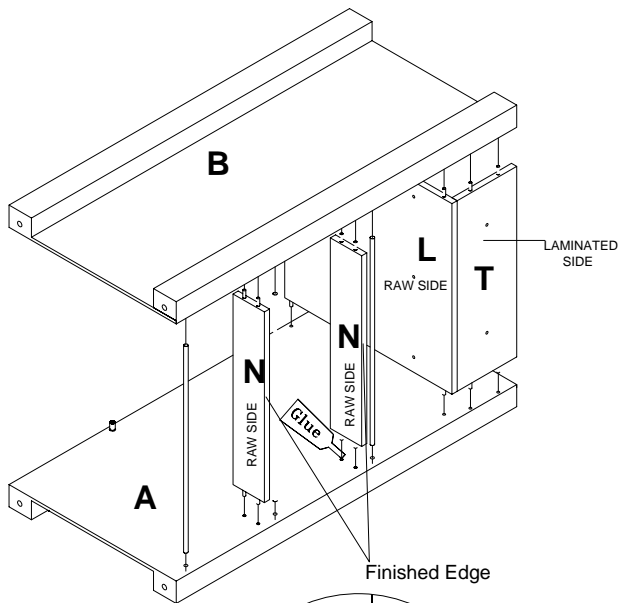
3

Make sure that there is no gap between connecting parts and raw or finished sides of parts are installed according to the diagram, because once glue has set you won't be able to undo this step. Leave the assembly on its side to let glue to dry, while you work on the next step.

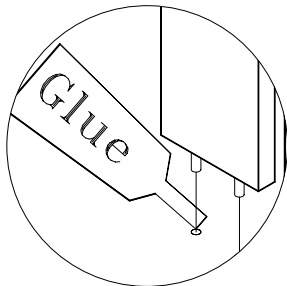

4

When first inserting camlocks, make sure they always point towards edge of board as indicated.

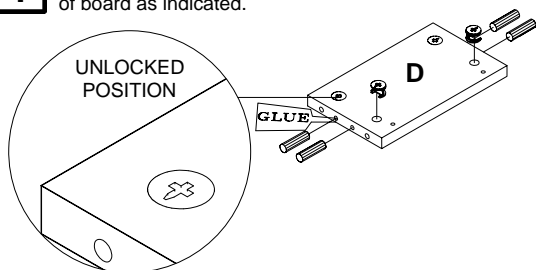

NOTE: Make sure the dowels go in as far as possible, they should stick out no more than $\frac{3}{8}$ of an inch.

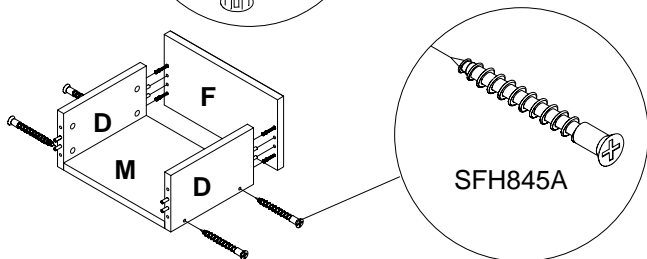
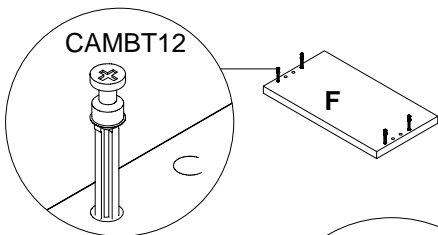

With four long screws, attach part (M) onto parts (D), as shown below.

5

Place part (H) onto the floor. Install assembly from previous step onto the door (H) and tighten camlocks.

When locked, arrow on camlock should point away from the edge as indicated.

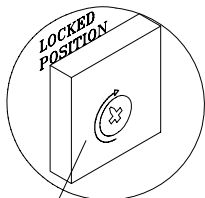

Turn camlock slightly over 1/2 turn until full stop

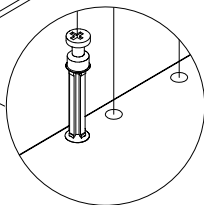
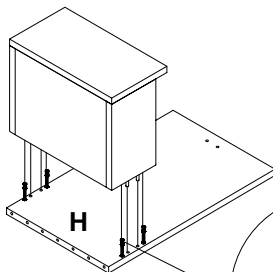

With seven flat head screws, attach the hinge to the door (H).

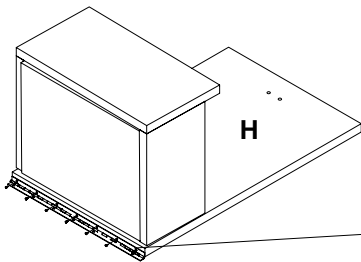

Holes are covered by laminate.

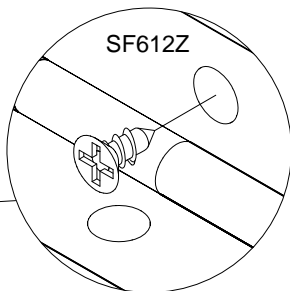

6

With seven flat head screws, attach the hinge to the base (E).

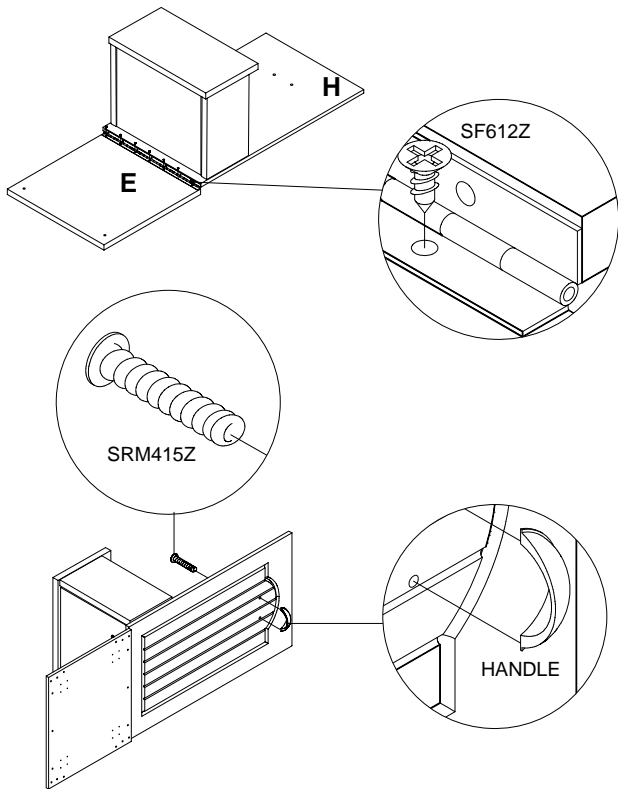

Attach the door handle onto the door (H), using the handle screws.

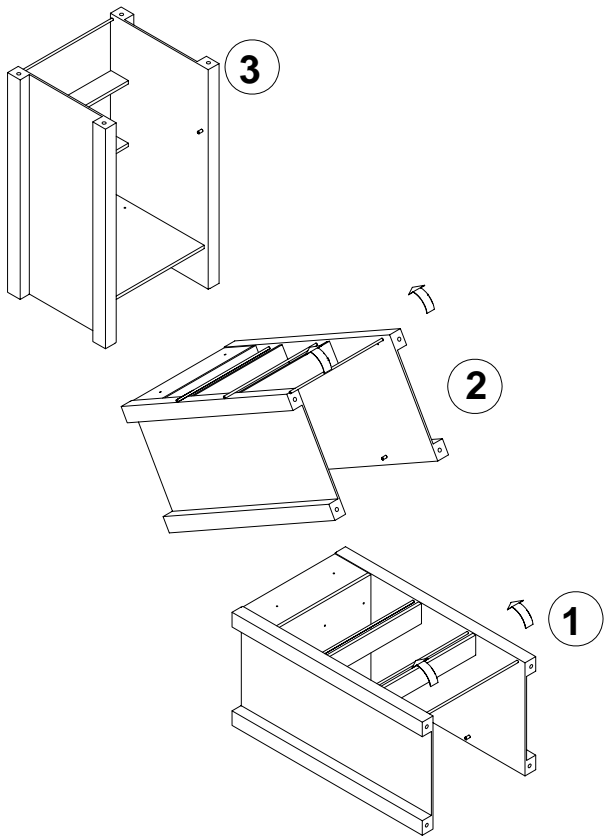
7

Please follow steps on this diagram to avoid breakage of parts.

8

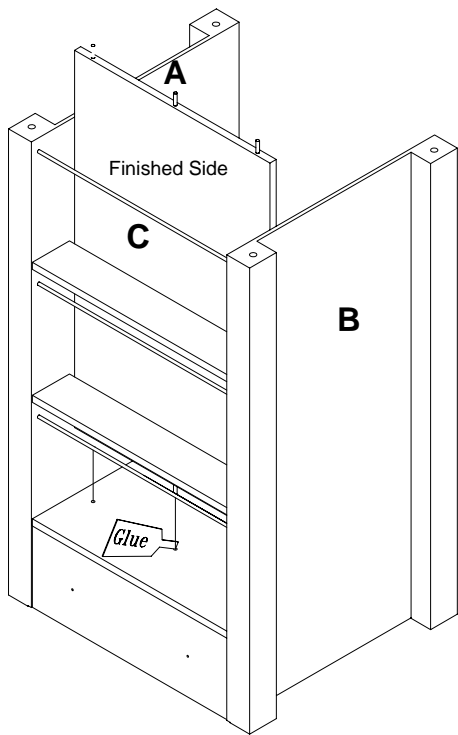

9

SCF50PZB

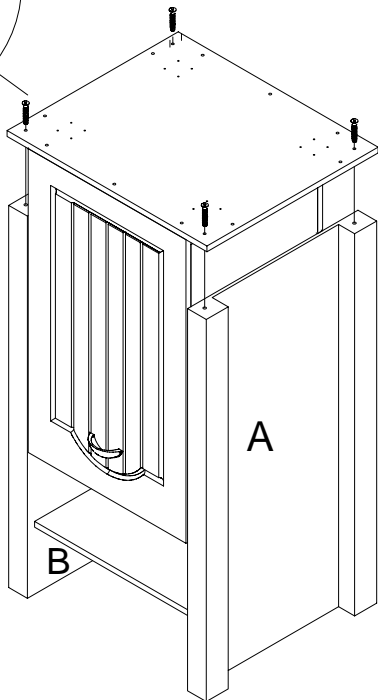

10

Apply one drop of glue in each hole with the wood dowels. Make sure the dowels go in as far as possible, they should stick out no more than $\frac{3}{8}$ of an inch. Use hammer to gently tap wood dowels in.

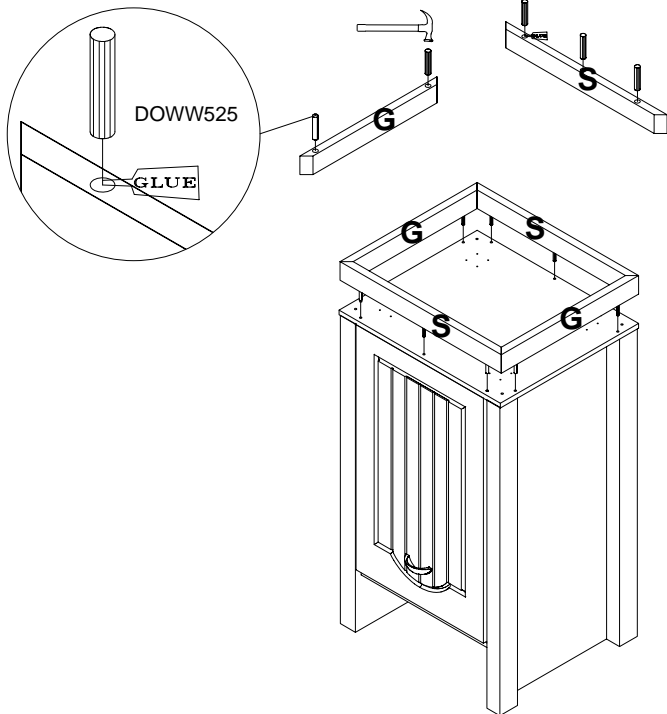

11

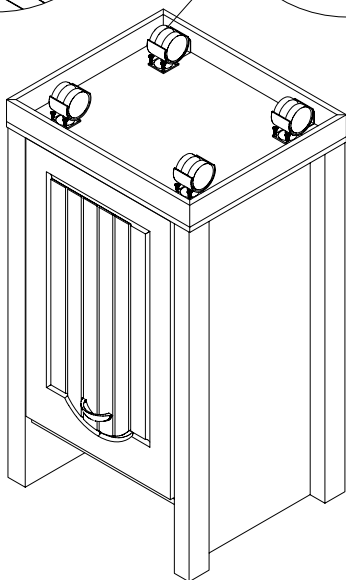
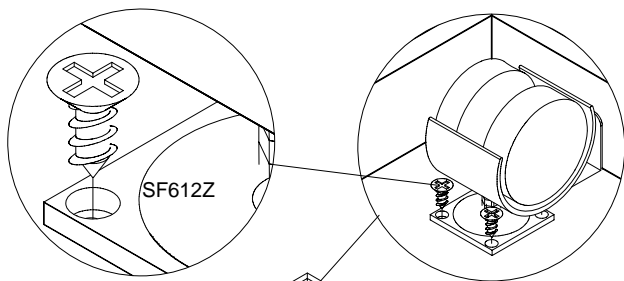

12

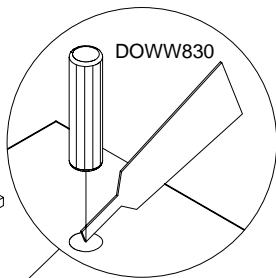
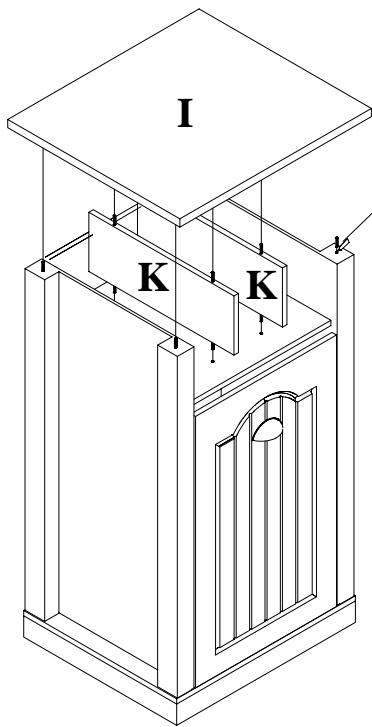

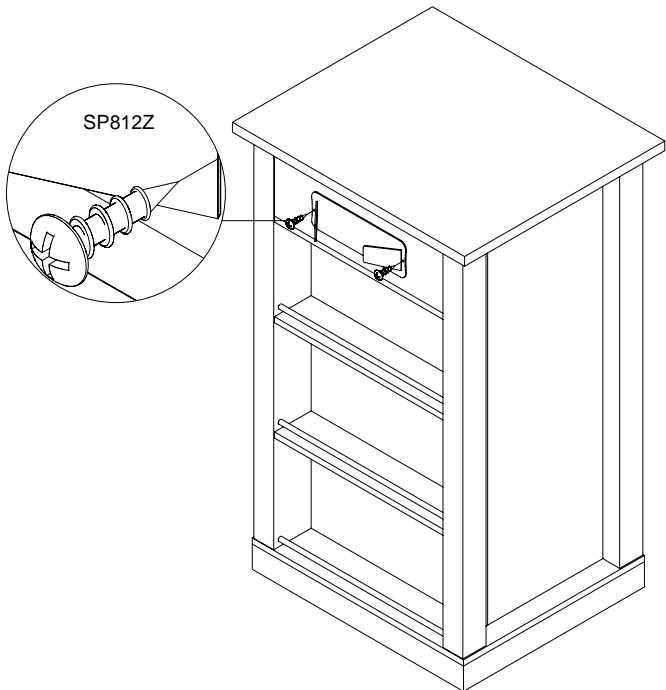
13

Most standard waste baskets under 20" of height and 15- $\frac{1}{2}$ " width should fit your unit. Just make sure at the bottom it is not greater than 14" wide and 10- $\frac{1}{2}$ " deep, so it can fit in the waste bin holder. Should you wish to use waste basket larger up to 14" by 11- $\frac{1}{2}$ " at the bottom then part (F) would have to be removed.

14

Stand the unit upright, clean and dust off the unit and it's ready for use. To protect wood from cracking drying -out, resist stains and to give it nice warm finish coat it with butcher block oil (mineral oil). Apply a small amount to a dry surface. Rub in using a clean cloth. Allow to penetrate. Re-apply as needed. If wood becomes stained, wet with water, spread juice of a lemon onto the surface. wait a few minutes and wipe off with damp cloth.

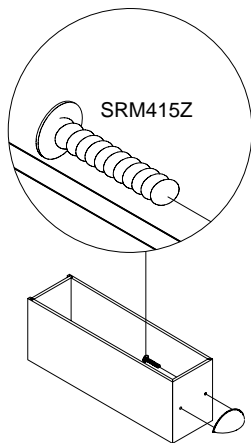
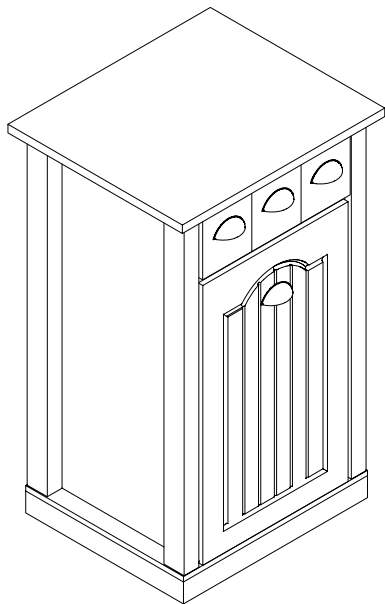

14

Stand the unit upright, clean and dust off the unit and it's ready for use. To protect wood from cracking drying -out, resist stains and to give it nice warm finish coat it with butcher block oil (mineral oil). Apply a small amount to a dry surface. Rub in using a clean cloth. Allow to penetrate. Re-apply as needed. If wood becomes stained, wet with water, spread juice of a lemon onto the surface. wait a few minutes and wipe off with damp cloth.

