



IF PARTS ARE MISSING AND OR DEFECTIVE, IF INSTRUCTIONS ARE NOT CLEAR
OR IF YOU ARE EXPERIENCING PROBLEMS ASSEMBLING OUR PRODUCT.

**BEFORE YOU RETURN THE PRODUCT TO THE STORE,
PLEASE CALL US TOLL FREE FOR CUSTOMER SERVICE ASSISTANCE**

(888) 777-8250







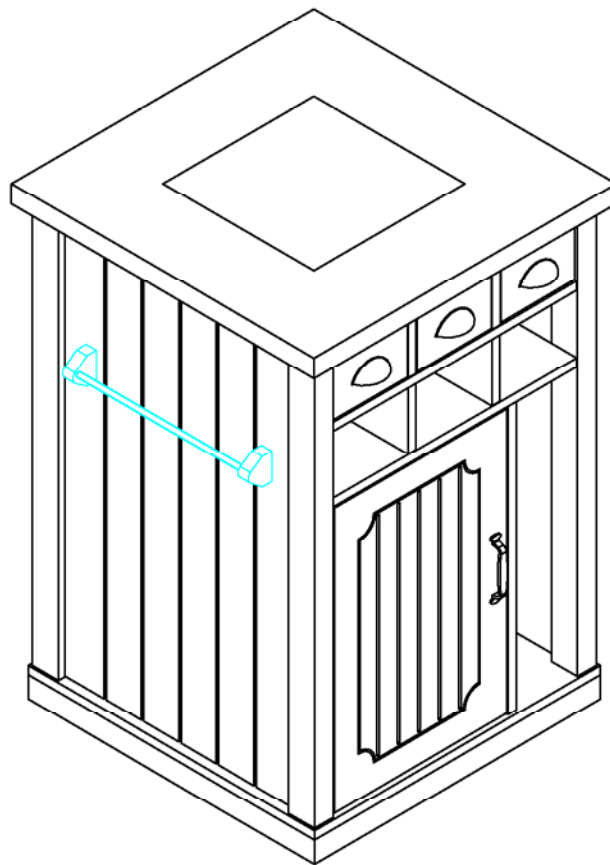



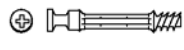



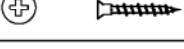

OR SEND US EMAIL AT

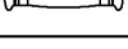
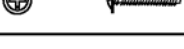
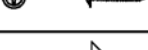
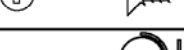
help@spartakent.com

PLEASE HAVE ITEM NUMBER READY, AND A REPRESENTATIVE WILL GLADLY ASSIST YOU

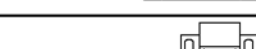

HARDWARE LIST

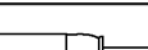
HARDWARE	PART #	DESCRIPTION	QTY
	CAMLT16	CAMLOCK	8
	CAMBT16	BOLT	8
	DOWW525	1" LONG WOOD DOWEL	78
	DOWW830	1-1/4" LONG WOOD DOWEL	4
	SP816BL	PAN HEAD SCREW	18
	SF612BL	FLAT HEAD SCREW #6 x 1/2	1
	SCF507HB	CONFIRMAT SCREW	6
	SFH825A	WOOD SCREW	8
	PUSHWOSN	SHELL METAL PULL	3
	HNDLMT96SN	HANDLE	3
	SRM810B	HANDLE SCREW	6
	SRM820B	HANDLE SCREW	6
	SF812Z	FLAT HEAD SCREW #8 x 1/2"	2
	CAS50	CASTER W/FLAT PLATE	4
	TOWWD	TOWEL BAR	2
	TOWPLWH	PAPER TOWEL HOLDER	1
	GLUEWD	GLUE	2
	MAGDBBL	DOUBLE MAGNET	1
	MAGSIBL	SINGLE MAGNET	1
	STPLTBL	MAGNETIC PLATE	1
	PHWDL	HINGE KIT	3
	ENDCAPWH5	HOLE PLUG	2
	DOWW	WOOD ROD	6

TOOLS REQUIRED

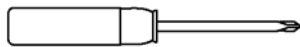

PHILLIPS SCREWDRIVER



HEX KEY

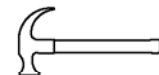

HAMMER

PARTS IDENTIFICATION

NOTE: FIRST MAKE SURE THAT YOU HAVE ALL OF THE PARTS LISTED ON THIS SHEET. IF YOU ARE MISSING ANY PIECE(S), DO NOT ASSEMBLE THE UNIT. INSTEAD, CALL CUSTOMER SERVICE NUMBER AT: (888) 777-8250. WE WILL BE HAPPY TO ASSIST YOU.

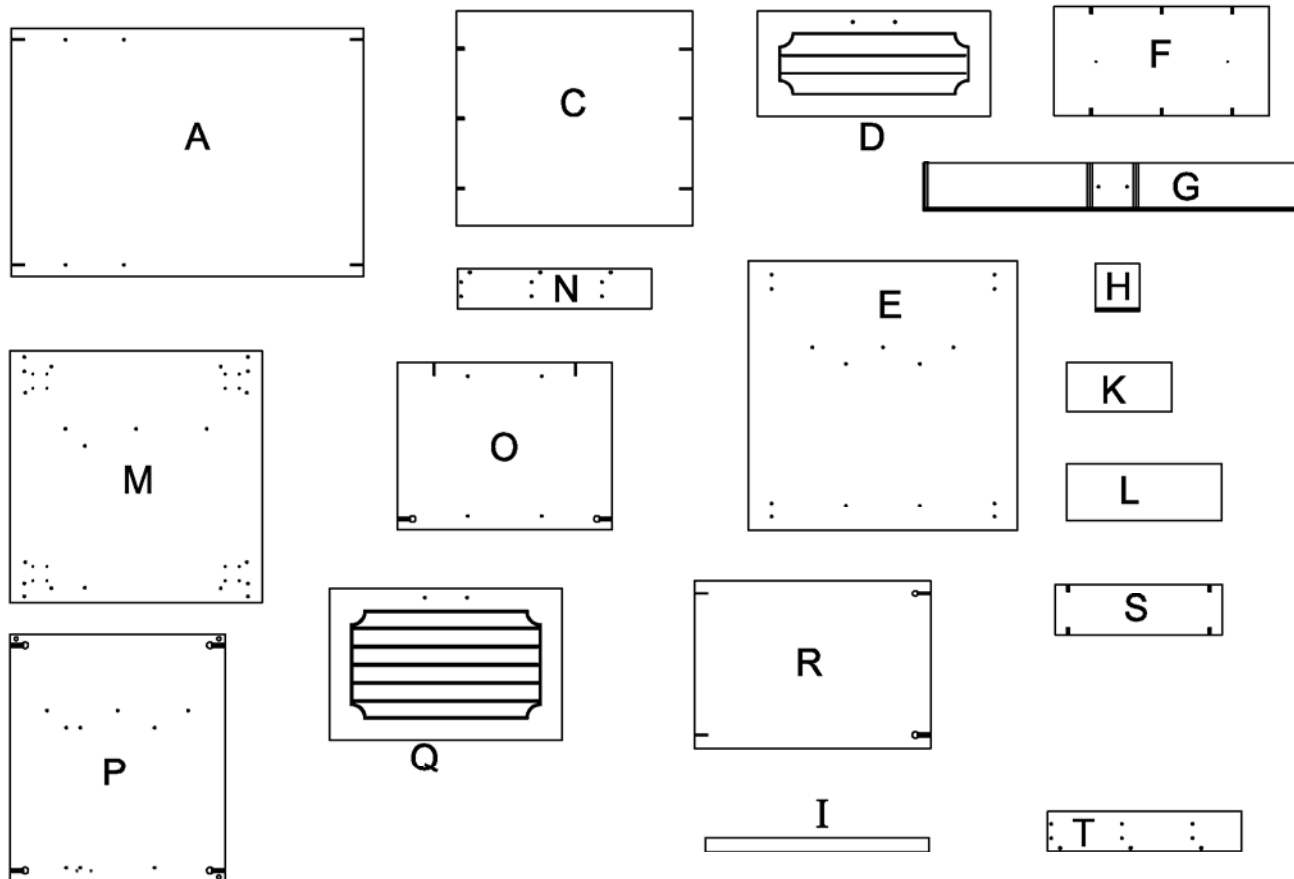

4101A-SIDE	2 PCS	4101K-SHELF	6 PCS
4101C-BACK	1 PC	4101L-DRAWER BOTTOM	3 PCS
4101D-DOOR	2 PCS	4101M-BASE	1 PC
4101E-TOP	1 PC	4101N-DOOR SIDE LEFT	2 PCS
4101F-BACK	1 PC	4101O-FIXED SHELF	1 PC
4101G-DR. MT. FOLD	3 PCS	4101P-FIXED SHELF	1 PC
4101H-DRAWER BACK	3 PCS	4101Q-DOOR	1 PC
4101 I-SKIRT	4 PCS	4101R-LOWER DIVIDER	1 PC
		4101S-UPPER DIVIDER	4 PCS
		4101T-DOOR SIDE RIGHT	2 PCS

PARTS ARE USUALLY MARKED ON THE RAW EDGE.

1

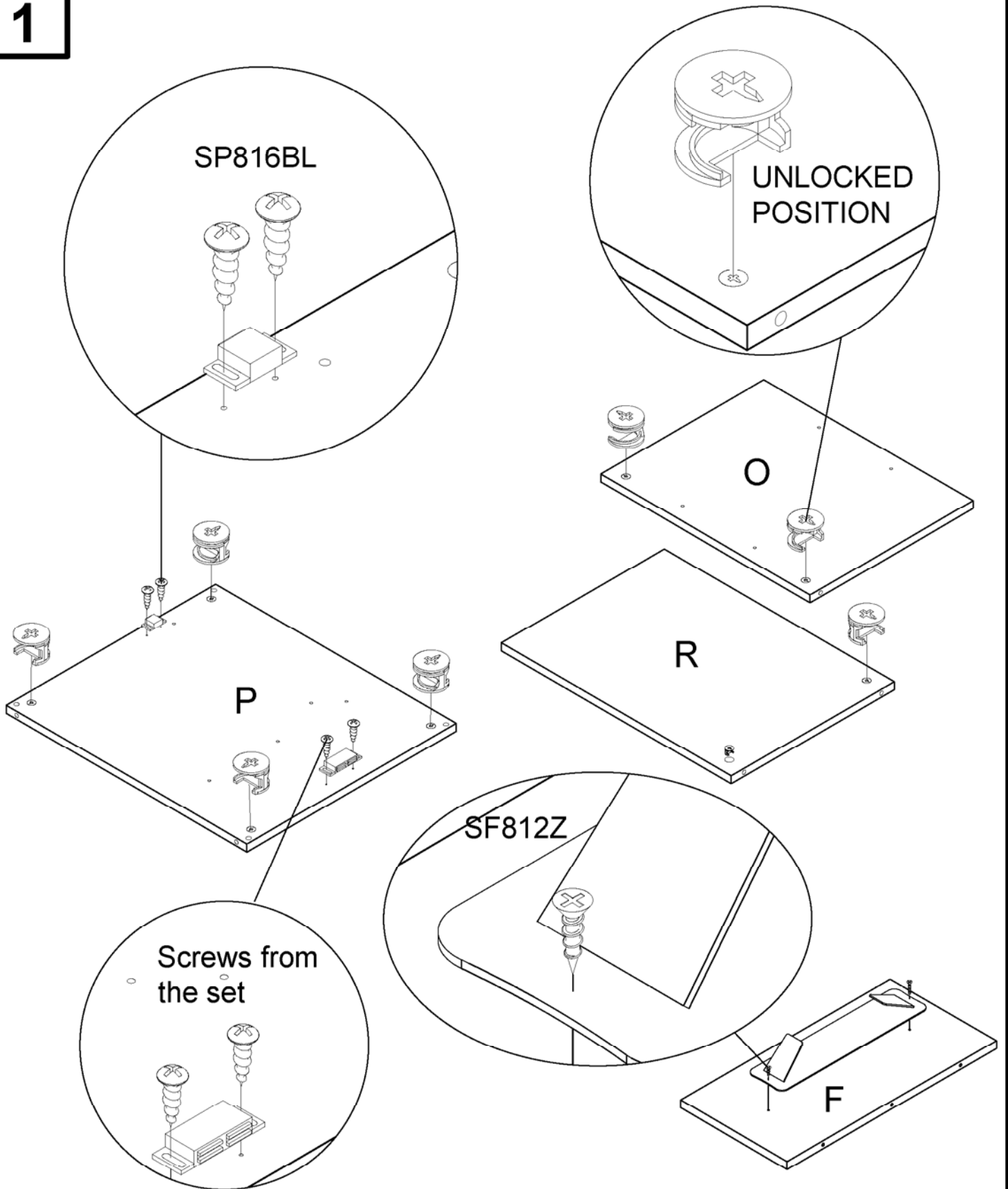

When first inserting camlocks, make sure they always point towards edge of board as indicated.

2 NOTE: Make sure the dowels go in as far as possible. They should stick out no more than 3/8 of an inch.

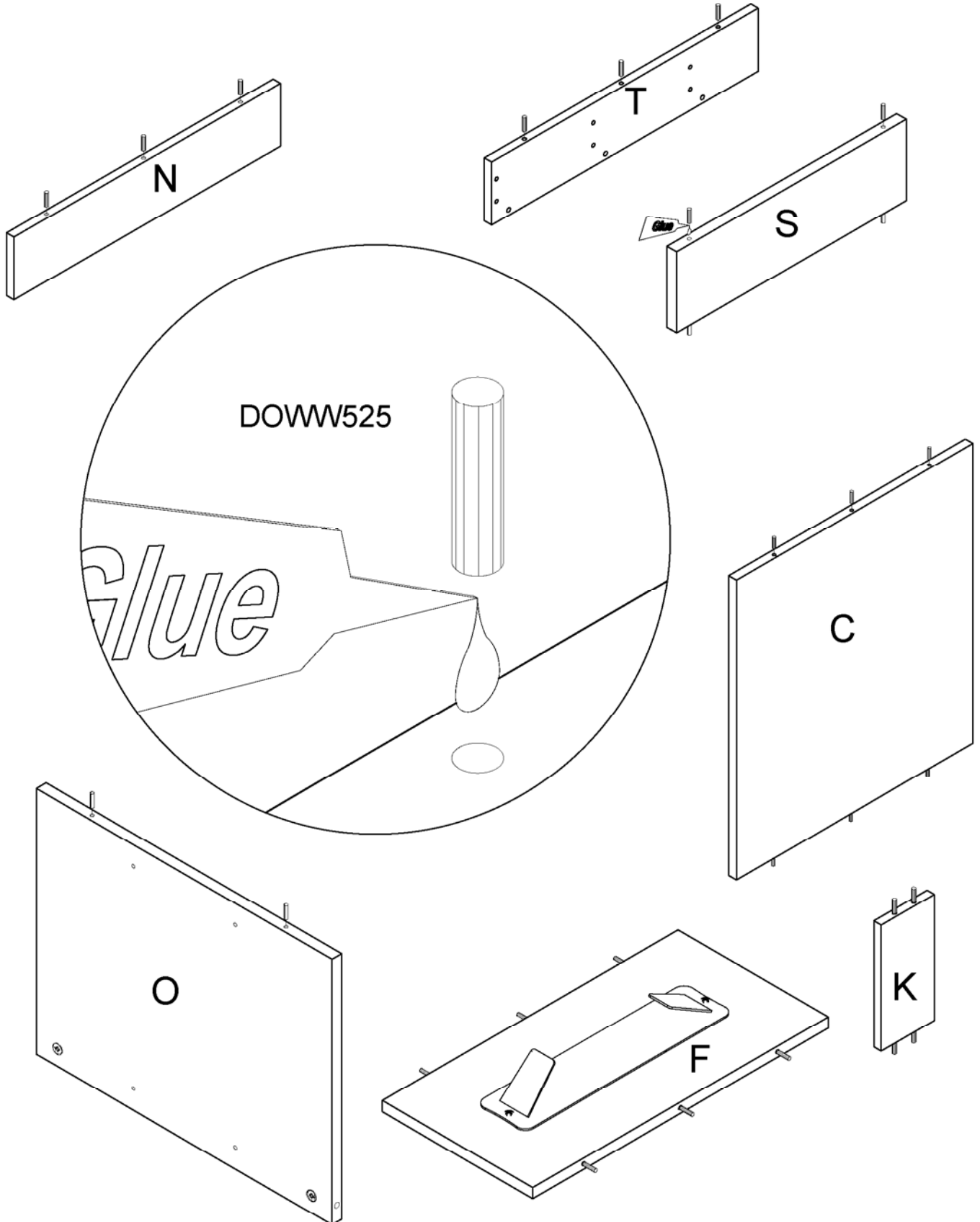

3

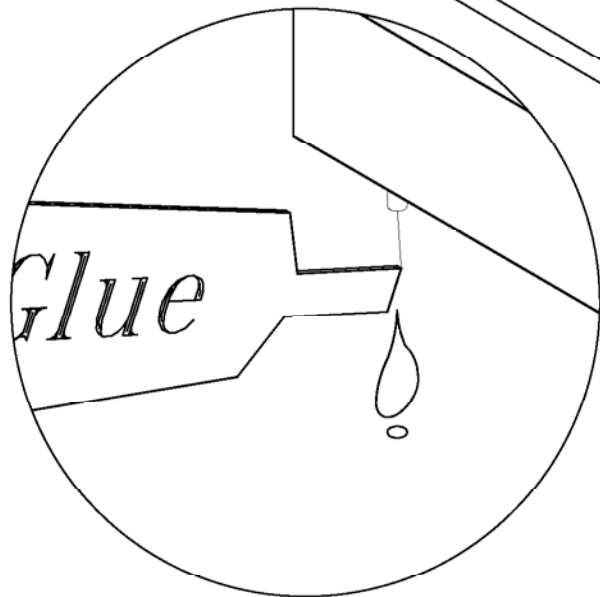
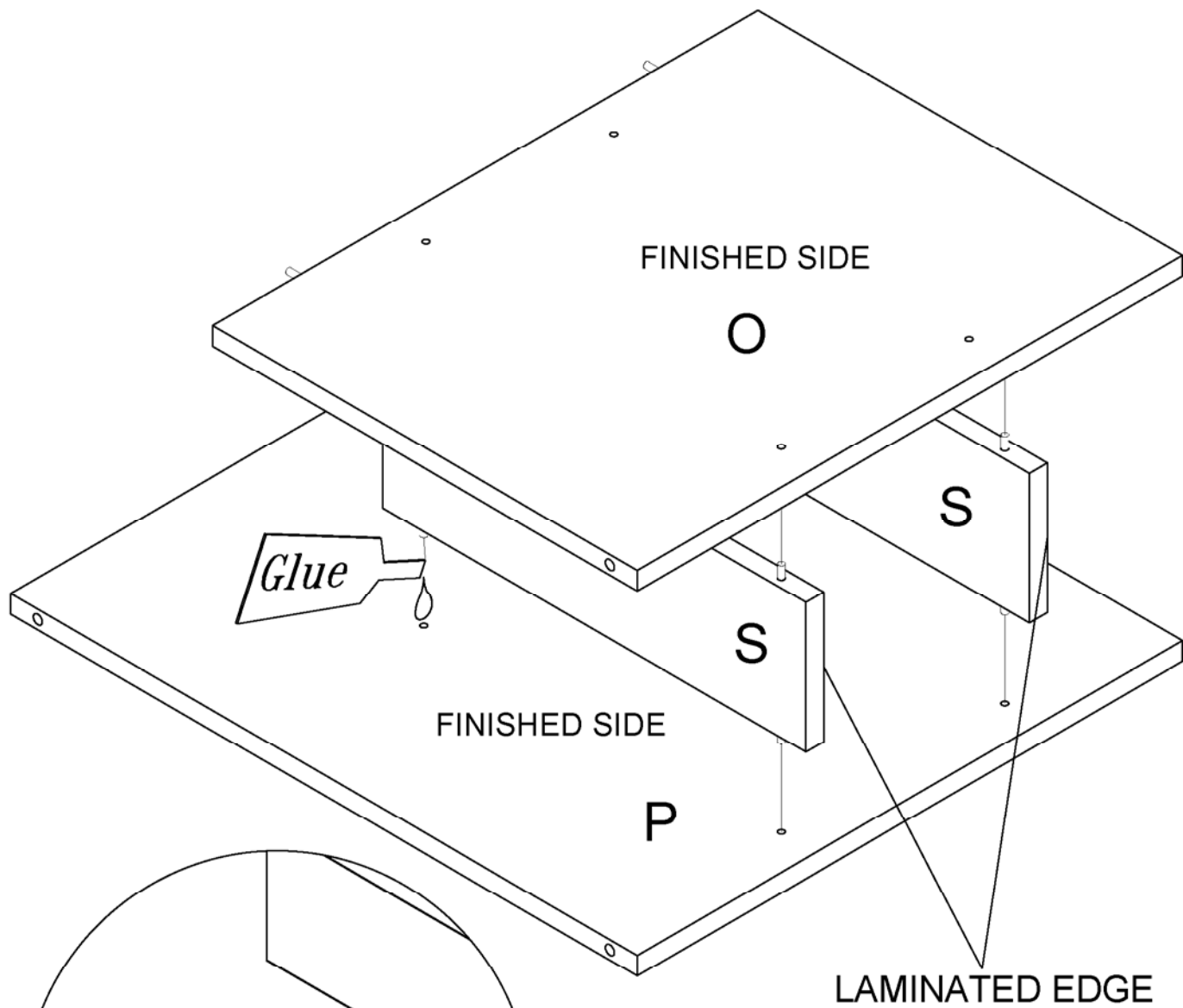

4

Instal bolts in parts A. You should leave one hole open on the opposite sides.

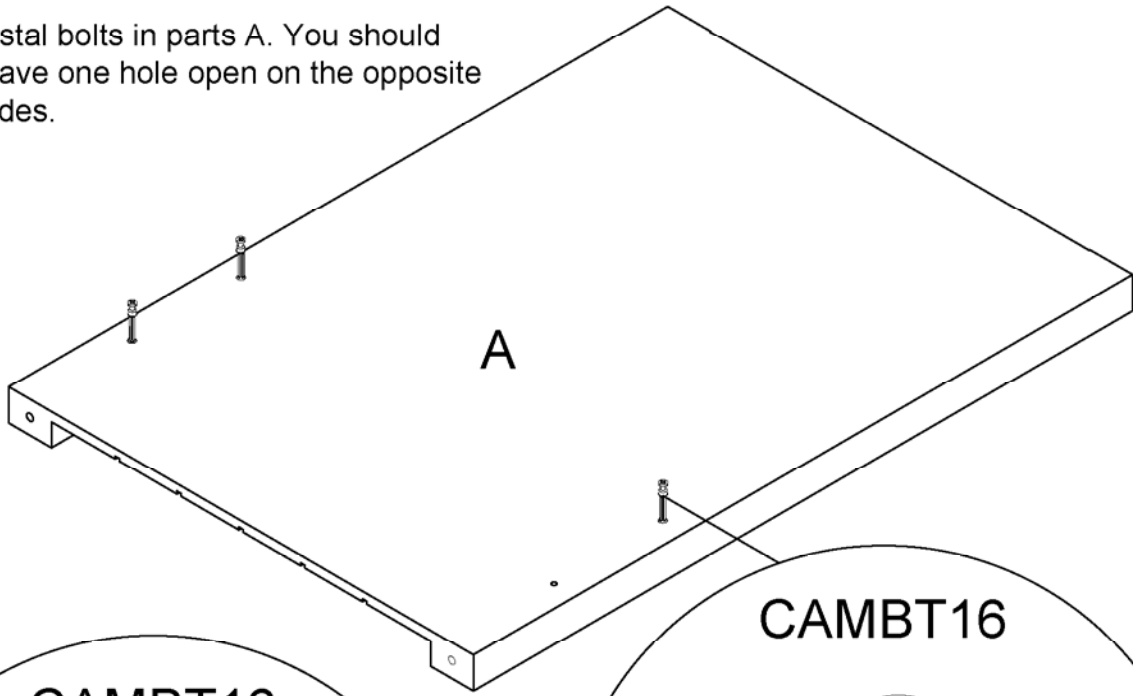

CAMBT16

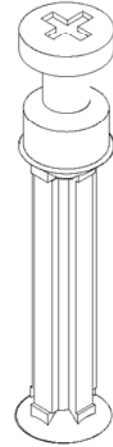

CAMBT16

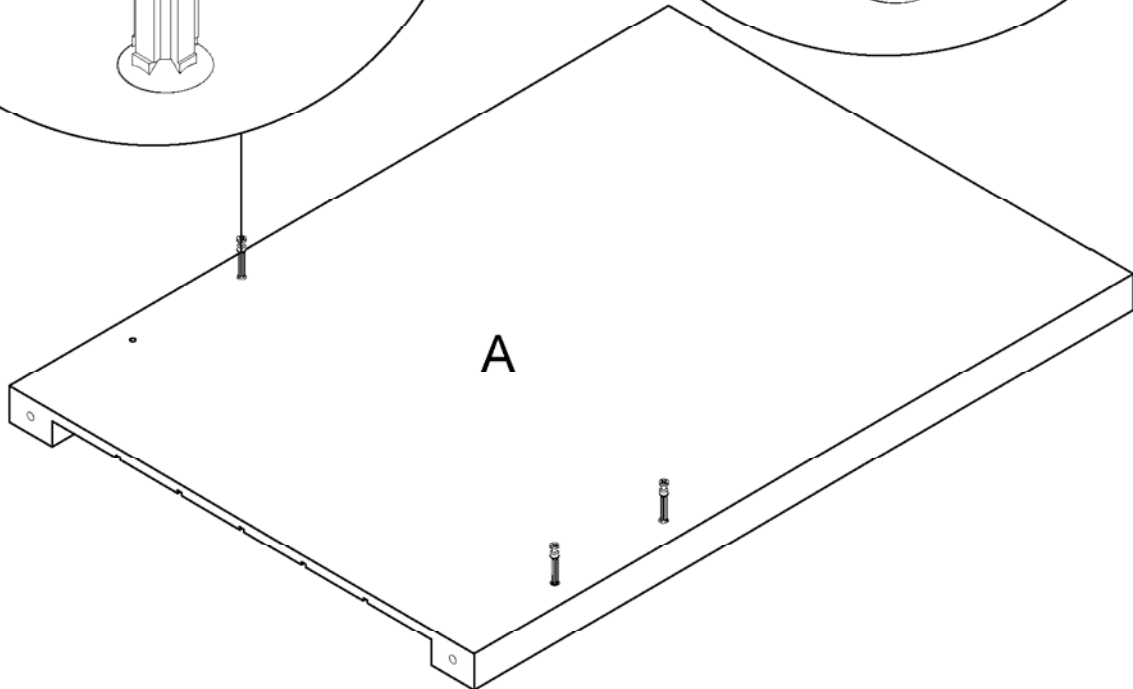
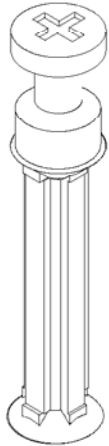

5

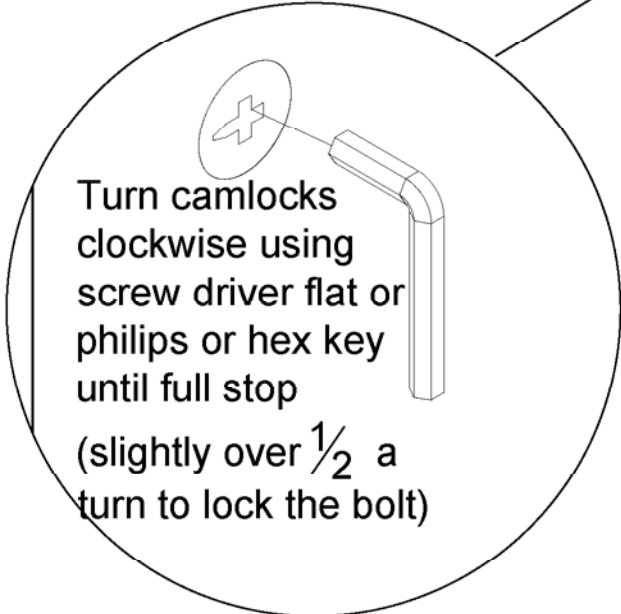
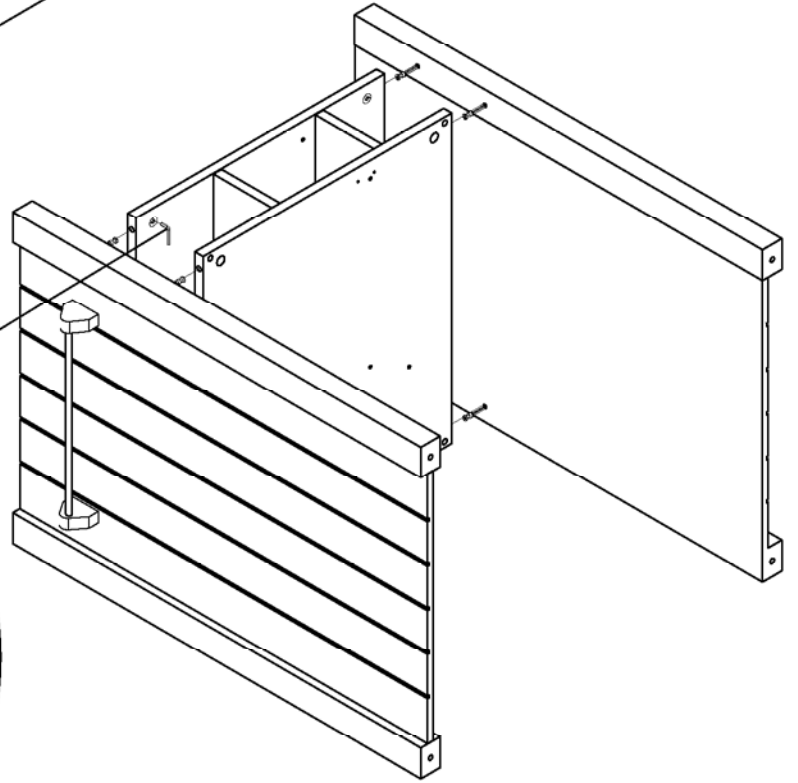
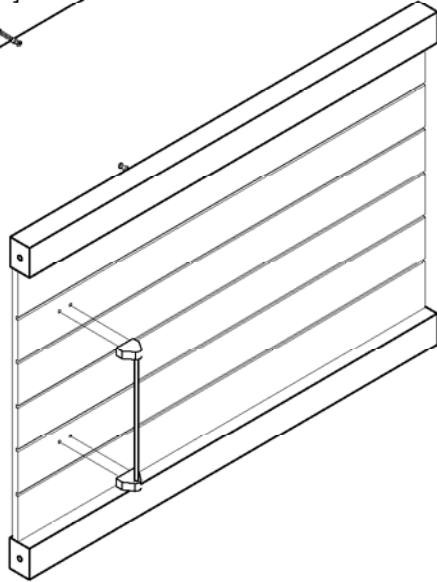
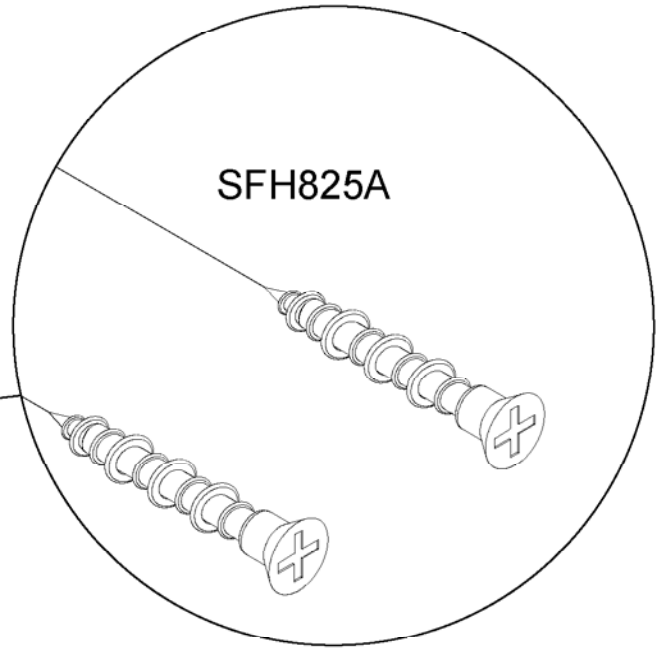
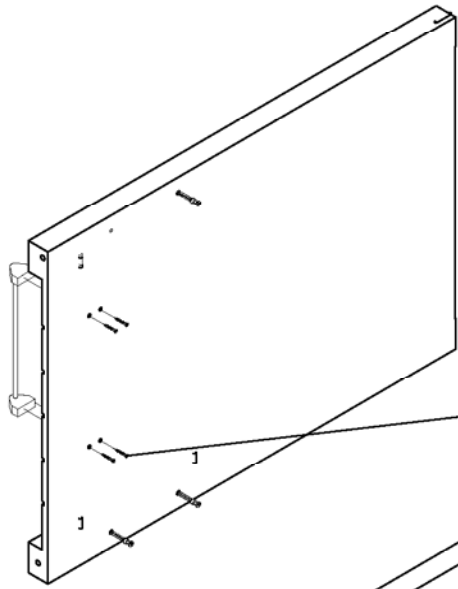

Turn camlocks clockwise using screw driver flat or philips or hex key until full stop (slightly over $\frac{1}{2}$ a turn to lock the bolt)

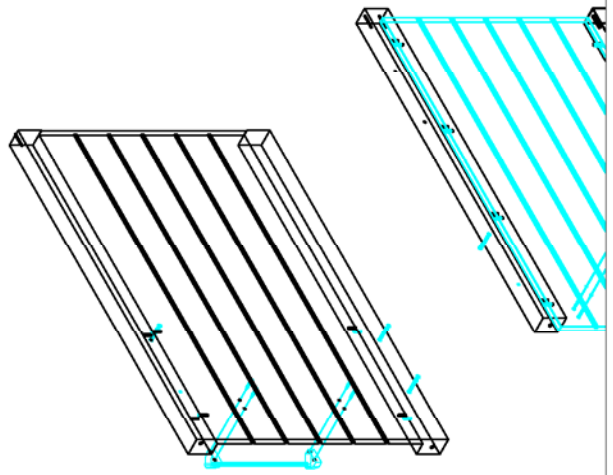

6

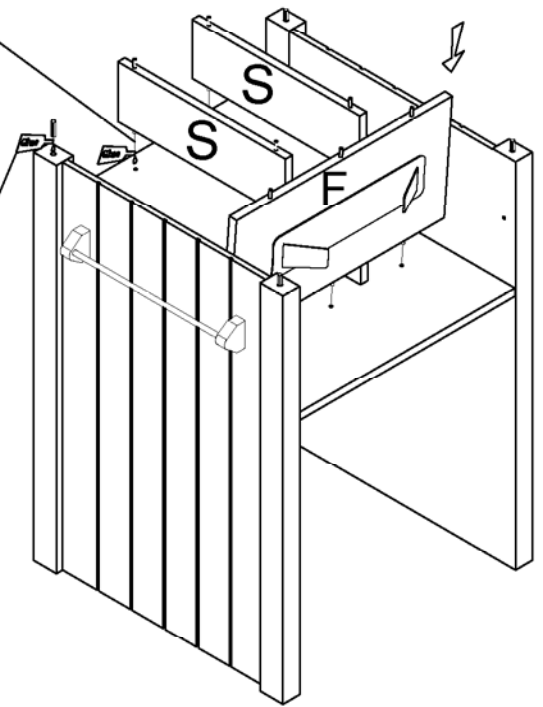
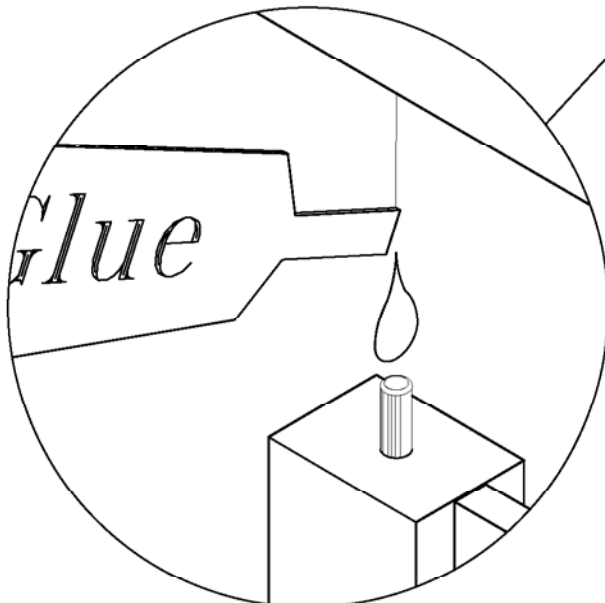
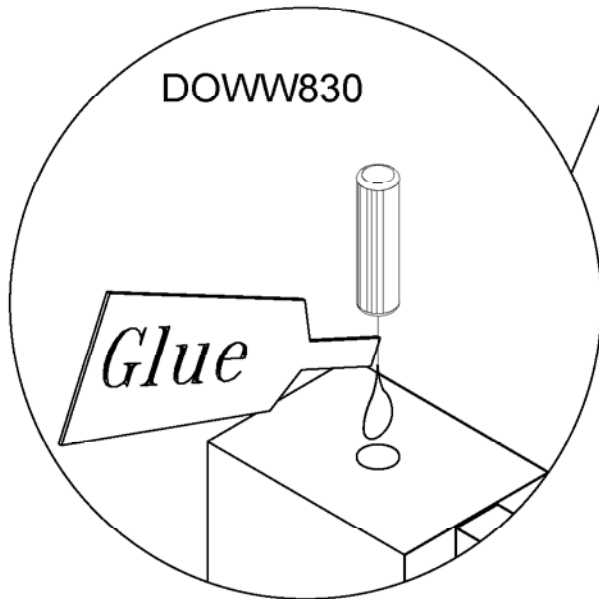
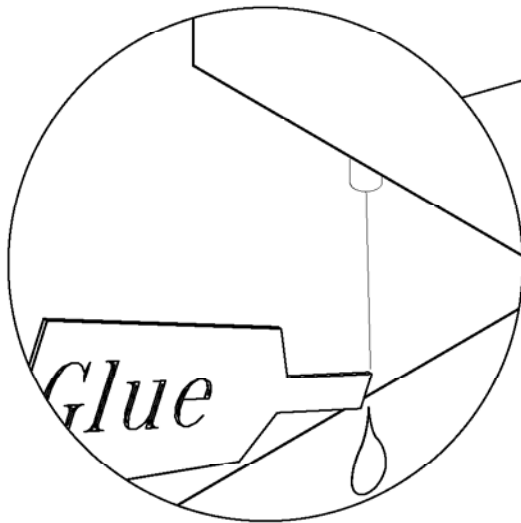

NOTE: Make sure the dowels go in as far as possible, they should stick out no more than $\frac{3}{8}$ of an inch. Use hammer to gently tap wood dowels in.

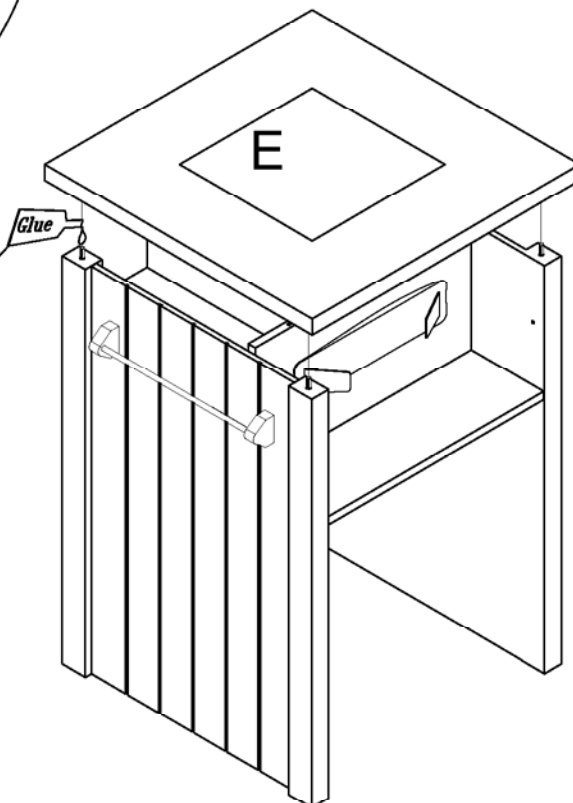

Dont leave a gap between sides and the top.

7

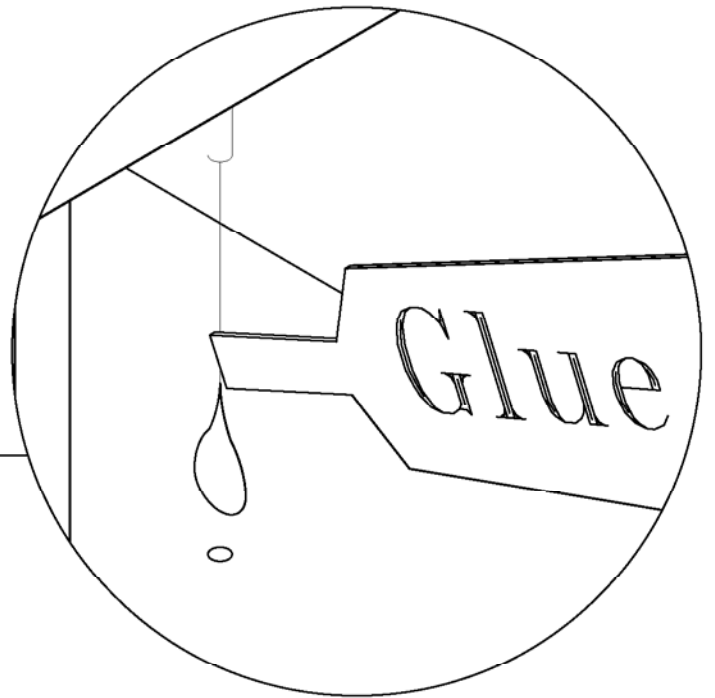
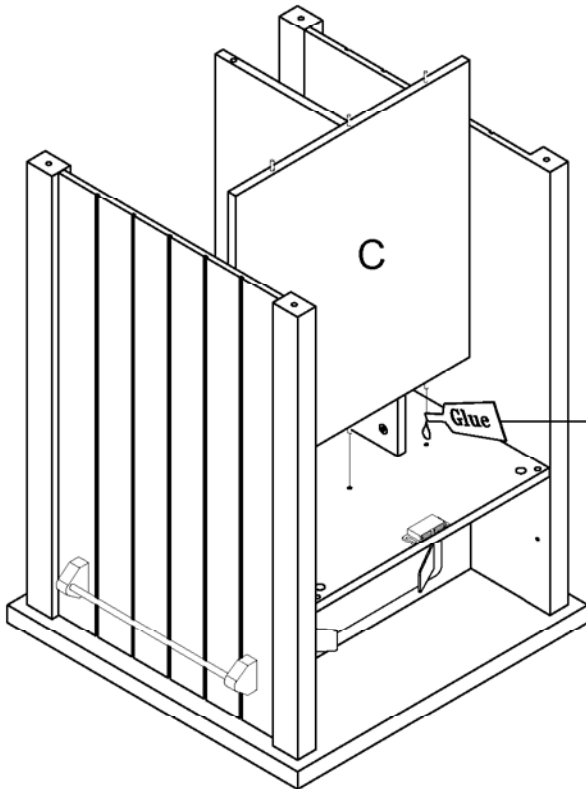
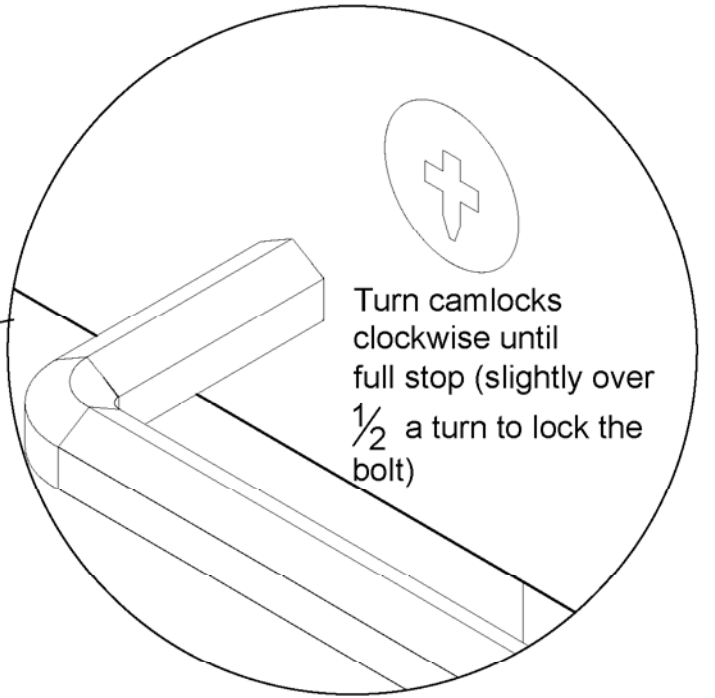
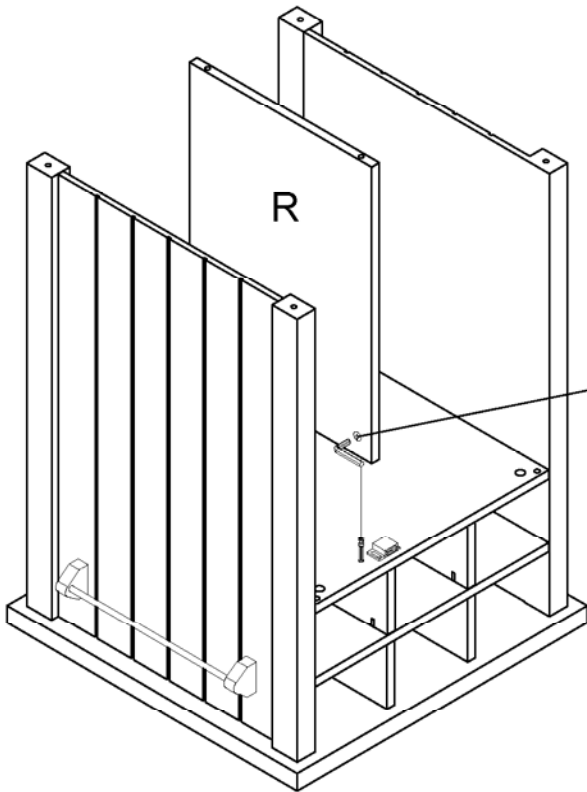

8

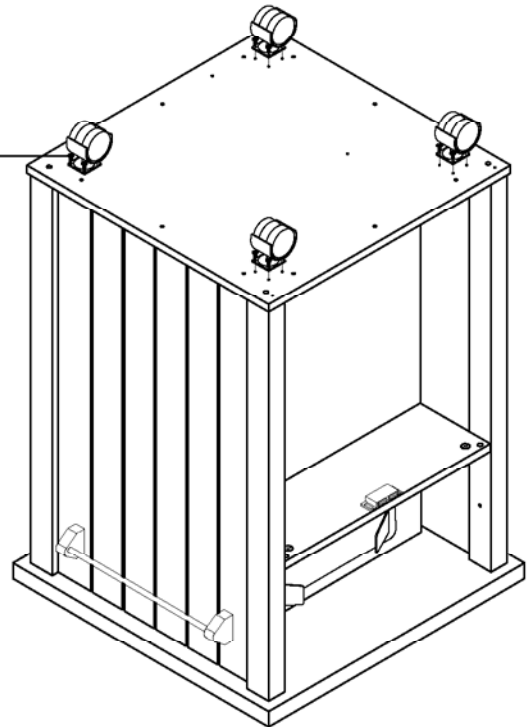
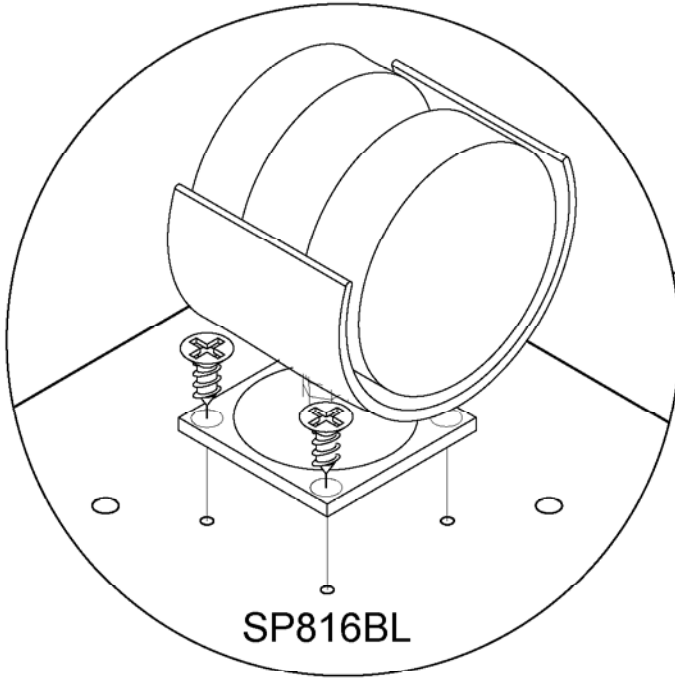
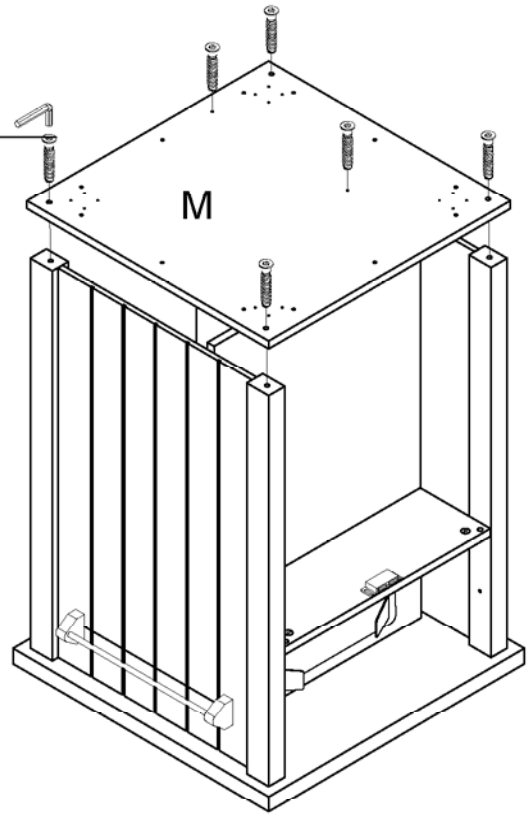
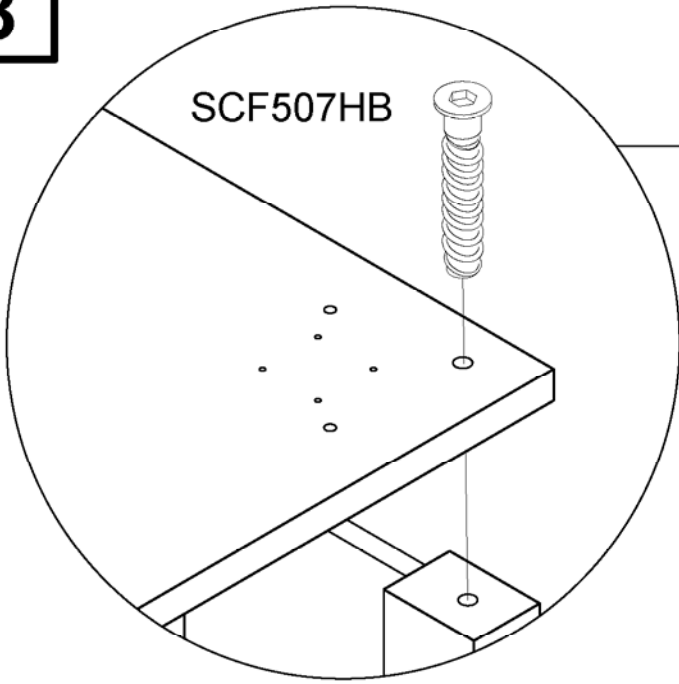

9

NOTE: Make sure the dowels go in as far as possible, they should stick out no more than 3/8 of an inch. Use hammer to gently tap wood dowels in.

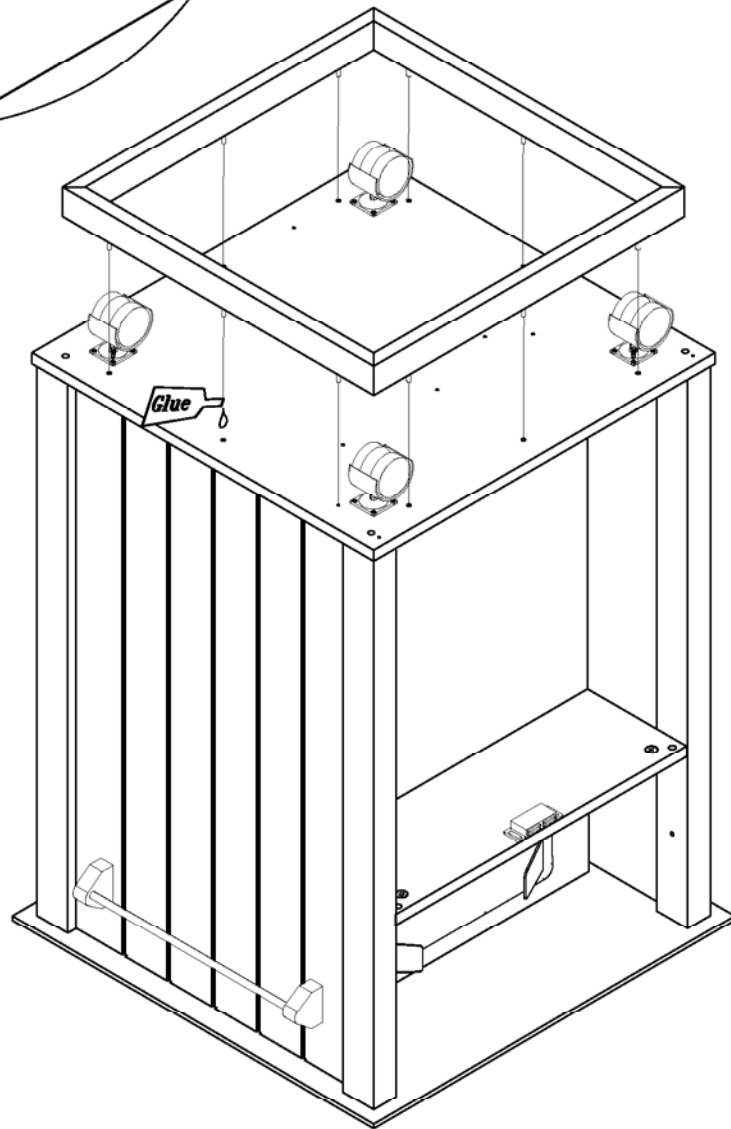
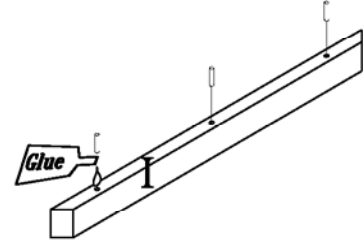
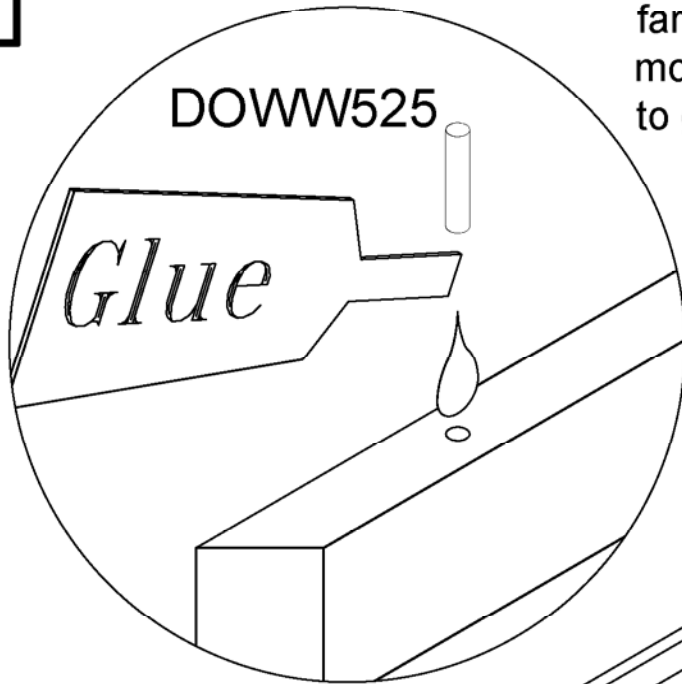

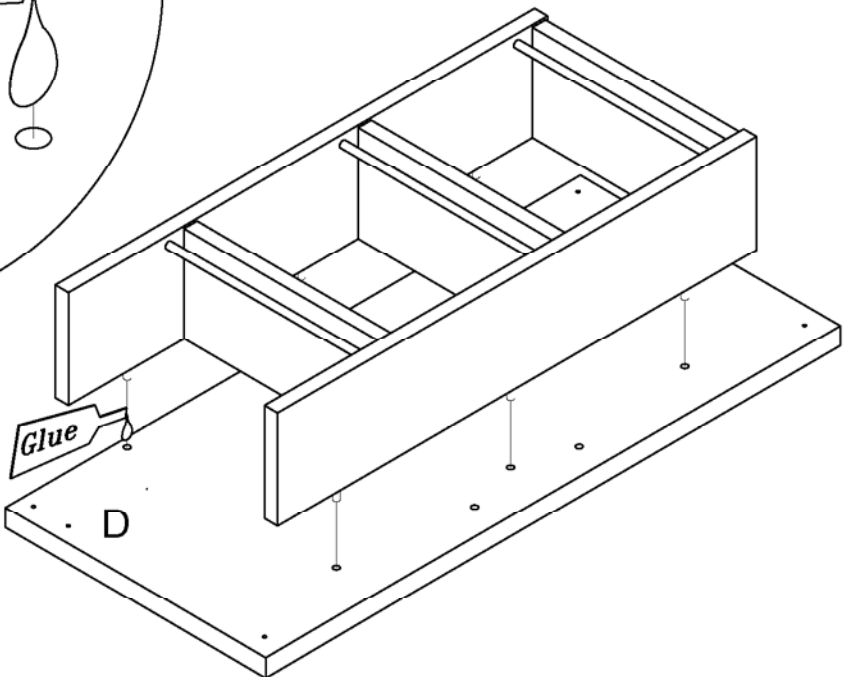
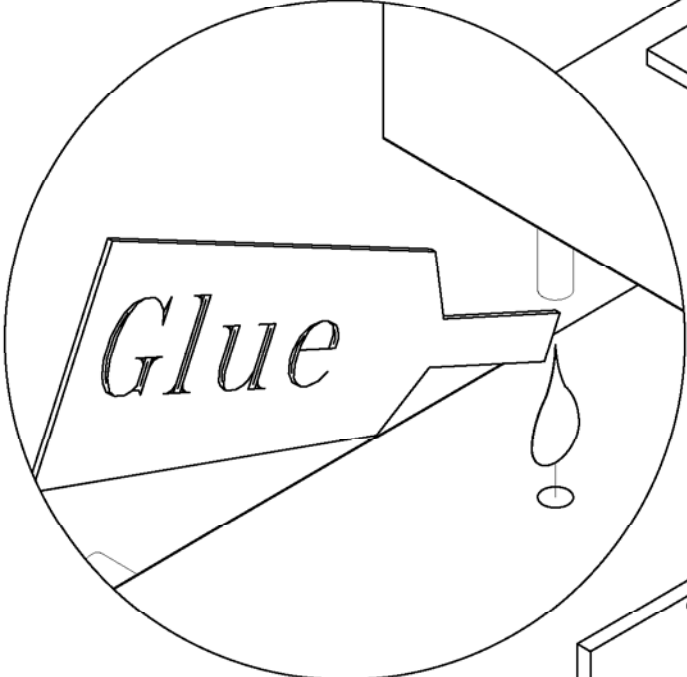
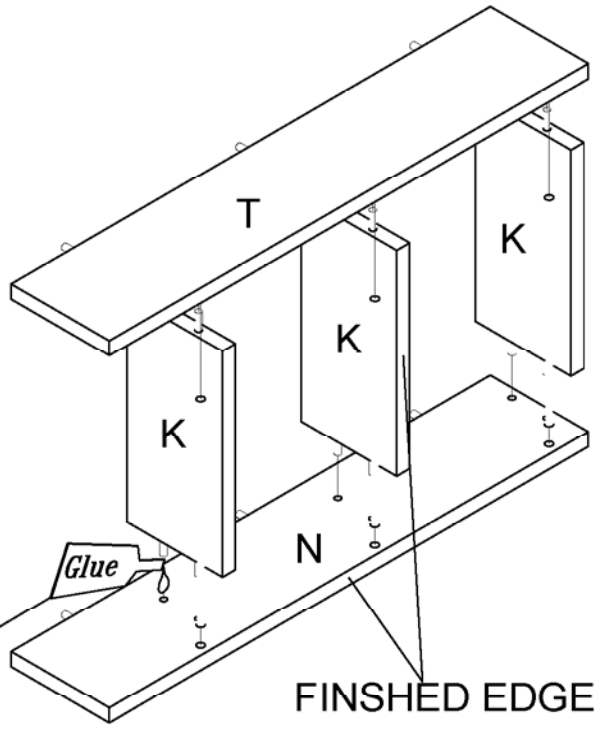

11

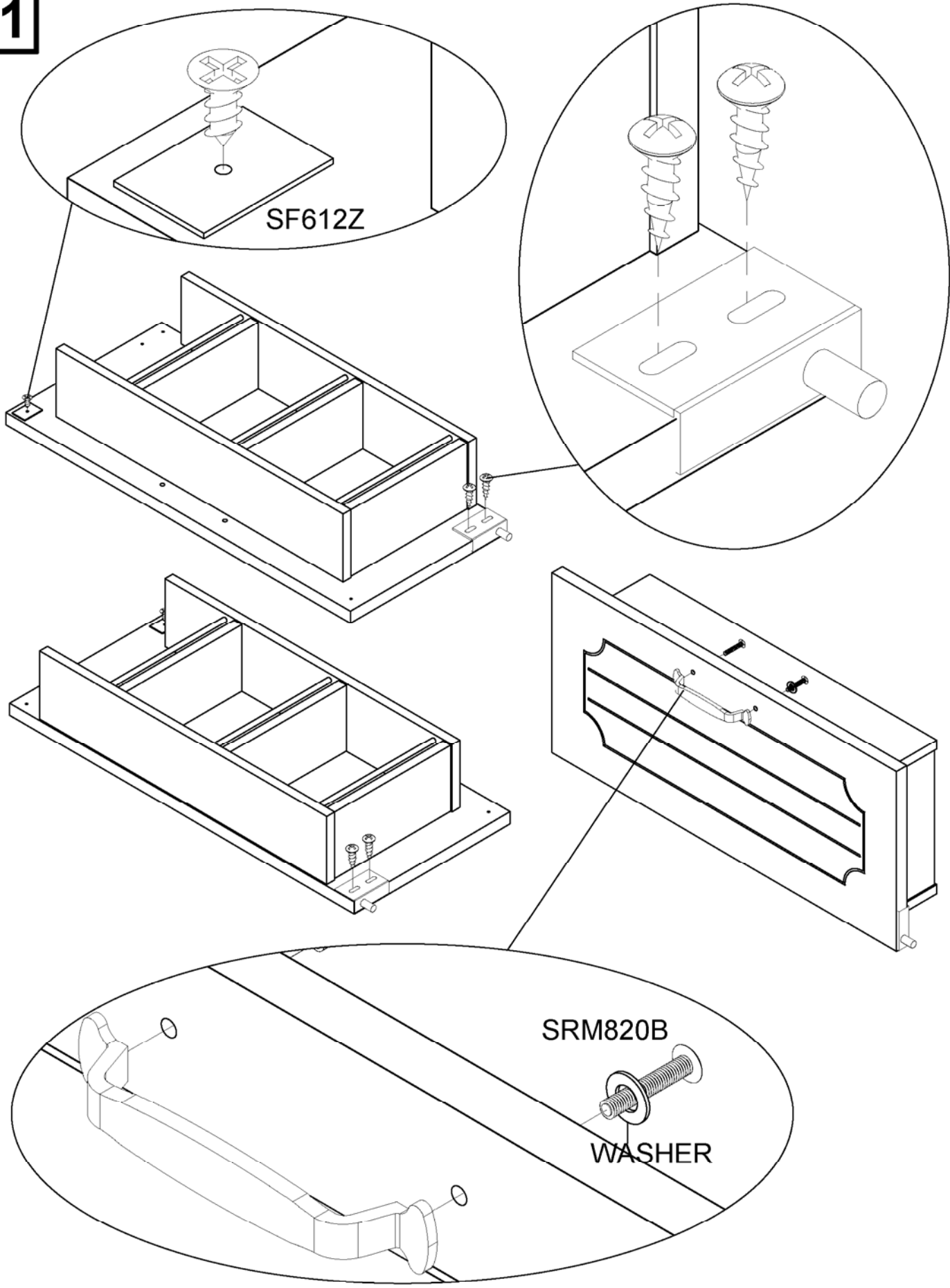

SF612Z

SRM820B

WASHER

We recommend you do one drawer at the time.

The excess of glue can be wiped off with a damp cloth. Also, once glue sets it will turn translucent and it will not stick to laminated surface and can be easily peeled off.

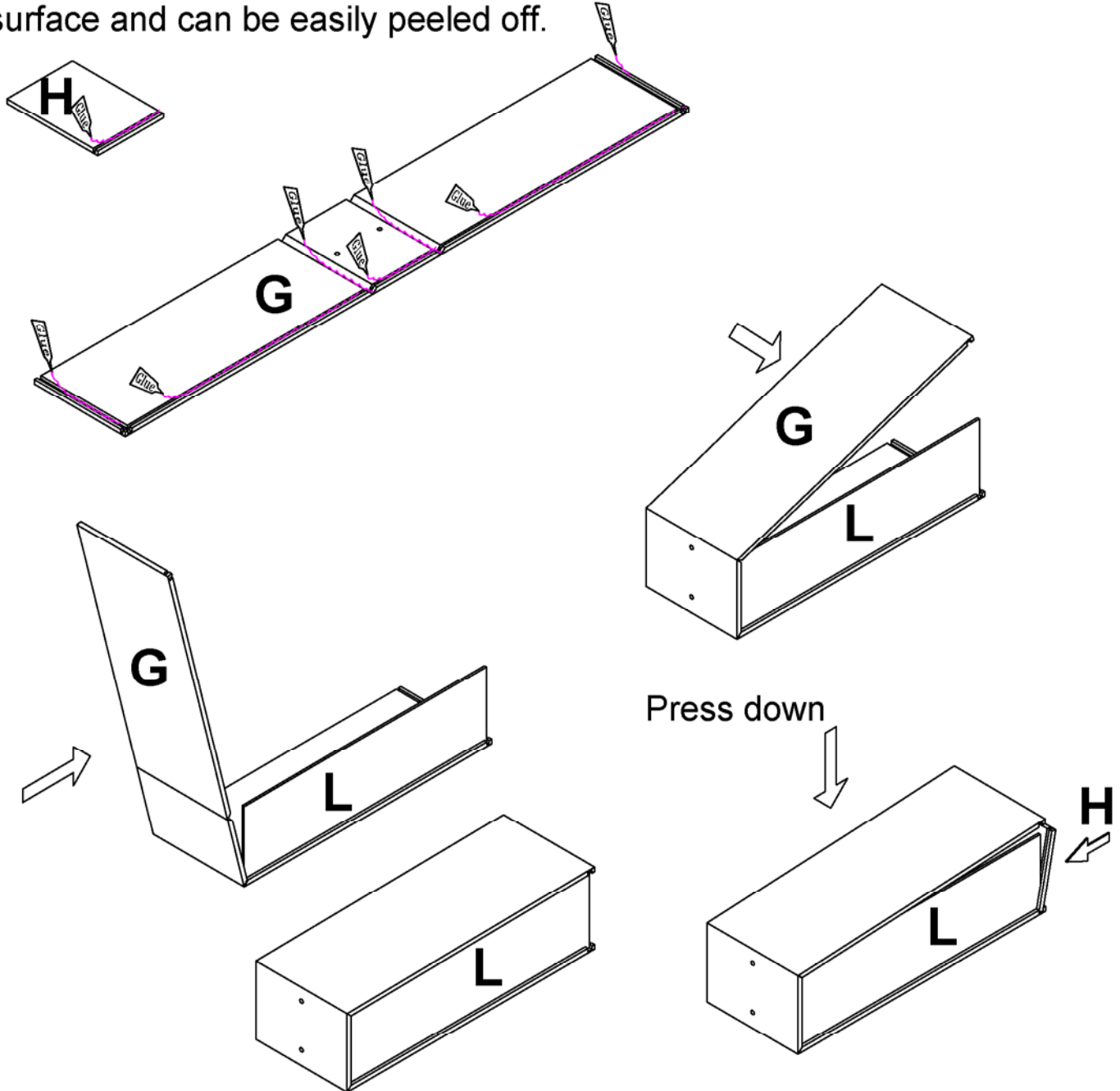

Allow glue to set at least for 2 hours. Repeat this step for the other two drawers. Make sure drawer back fits snug and there are no gaps. Leave drawers on their side until glue has set. You may put weight on it, like couple of books to apply pressure. In the mean time you can complete assembly of the island.

13

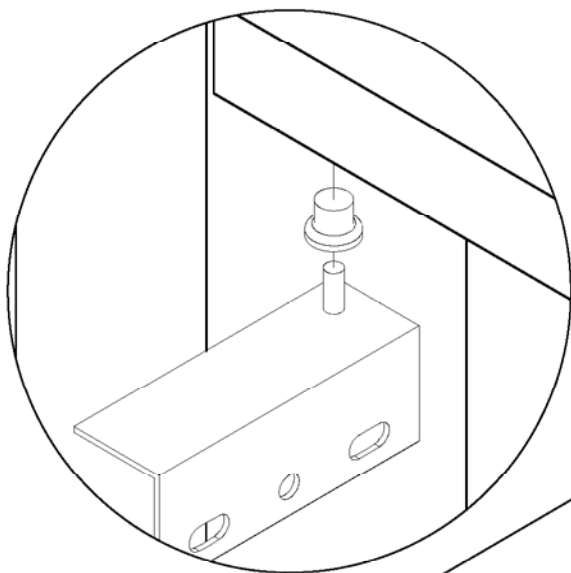

Cover the extra hole with white hole plug.

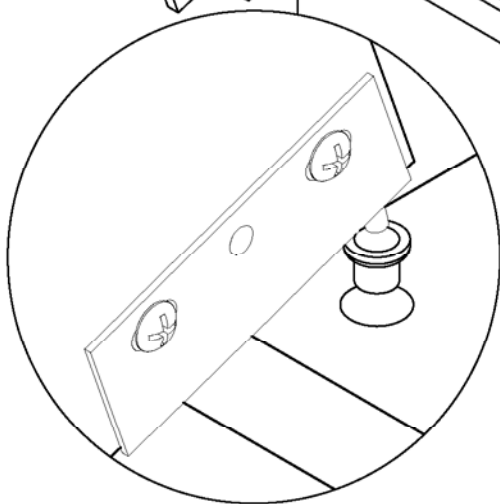
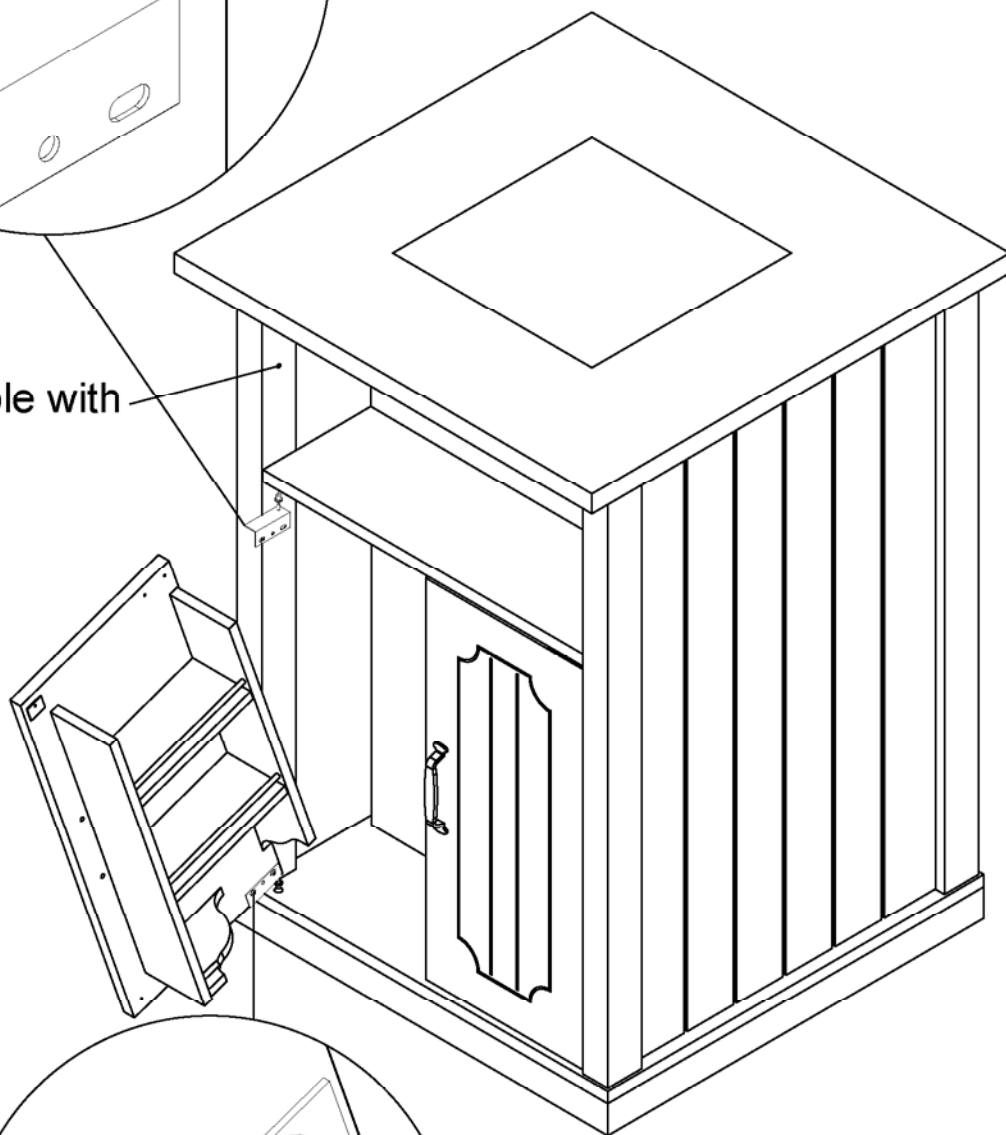

14

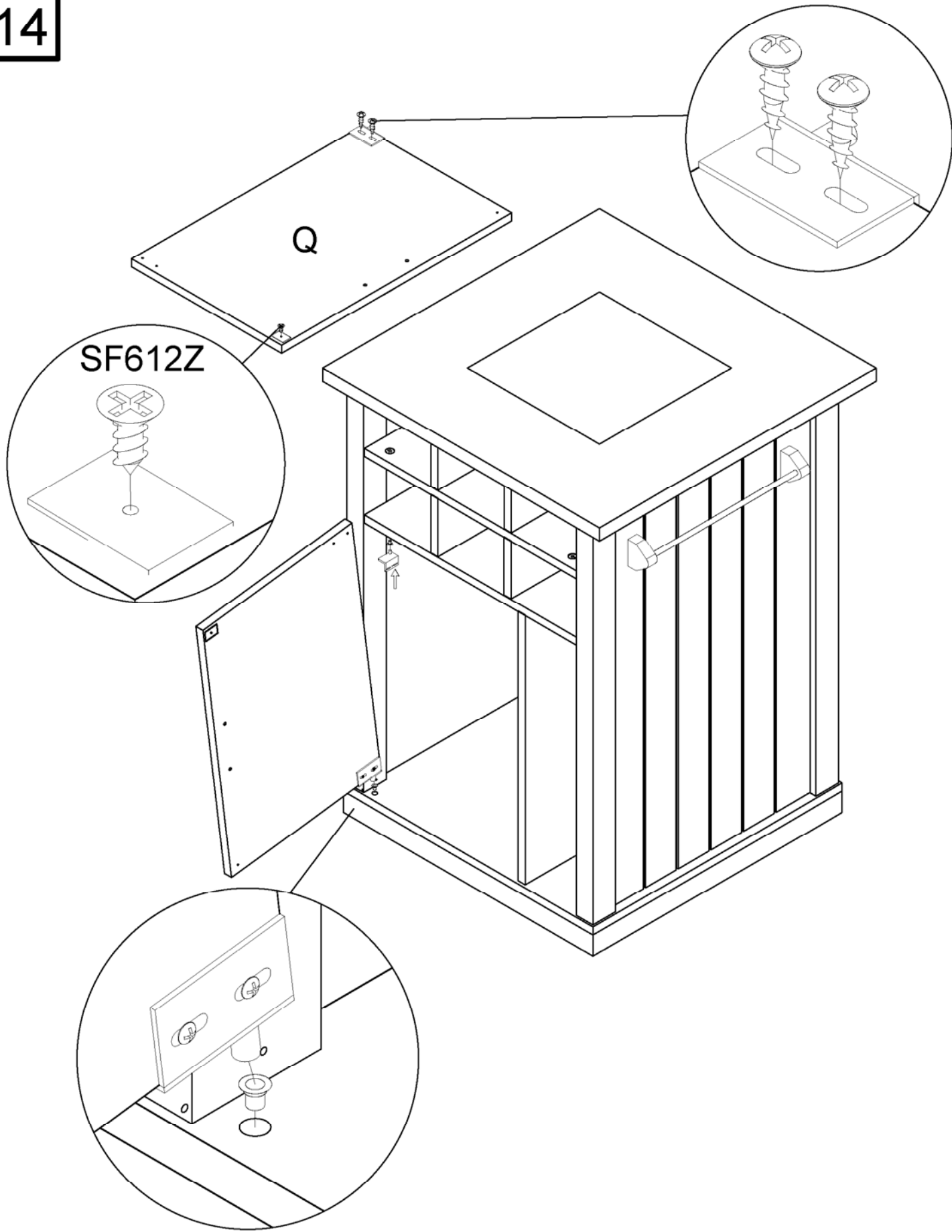

15

Stand the unit upright. Clean and dust off the unit and it's ready for use.

To protect wood from cracking drying-out, resist stains and to give it nice warm finish coat it with butcher block oil (mineral oil).

Apply a small amount to a dry surface. Rub in using a clean cloth. Allow to penetrate. Re-apply as needed.

If wood becomes stained, wet with water, spread juice of a lemon onto the surface. Wait a few minutes and wipe off with damp cloth.

