



**BEFORE YOU RETURN THE PRODUCT TO THE STORE,  
PLEASE CALL US TOLL FREE FOR CUSTOMER SERVICE ASSISTANCE**

**(888) 777-8250**







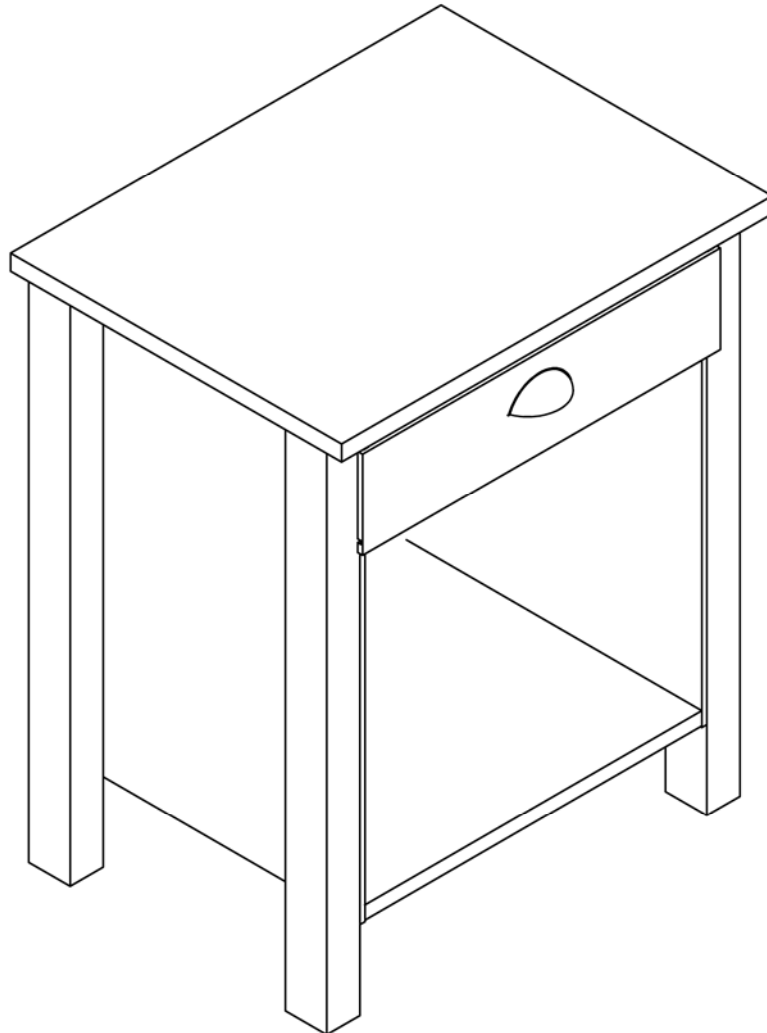





**OR SEND US EMAIL AT**

**[help@spartakent.com](mailto:help@spartakent.com)**

**PLEASE HAVE ITEM NUMBER READY, AND A REPRESENTATIVE WILL GLADLY ASSIST YOU**



# HARDWARE LIST

HARDWARE	PART NUMBER	DESCRIPTION	QTY
 	CAMLT12	CAMLOCK	8
	CAMBT16	BOLT	8
	DOWW830	WOOD DOWEL	8
	GLIDE22MM	GLIDE	4
	PUSH	SHELL METAL PULL	1
	SPTS819T25	HANDLE SCREW	2
	GLUEWD	GLUE	1
	SFH833A	WOOD SCREW	4
	BM25	ANGLE BRACKET	4
	SPE610BL	EURO SCREW	8
	SCXXS	SCREW COVER CAP	4
	SP811BL	PAN HEAD SCREW	8

# PARTS IDENTIFICATION

NOTE: FIRST MAKE SURE THAT YOU HAVE ALL OF THE PARTS LISTED ON THIS SHEET. IF YOU ARE MISSING ANY PIECE(S), DO NOT ASSEMBLE THE UNIT. INSTEAD, CALL OUR CUSTOMER SERVICE NUMBER AT: (888) 777-8250. WE WILL BE HAPPY TO ASSIST YOU.

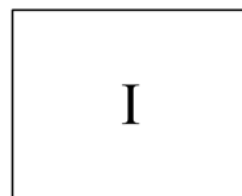
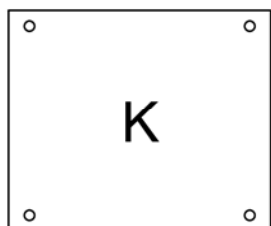
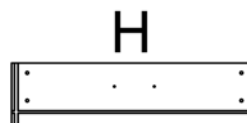
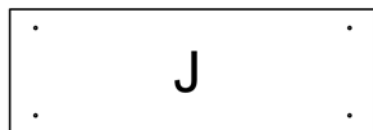
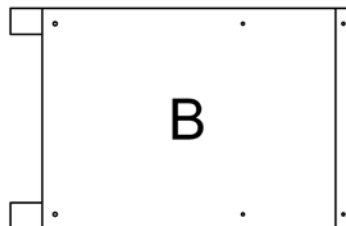
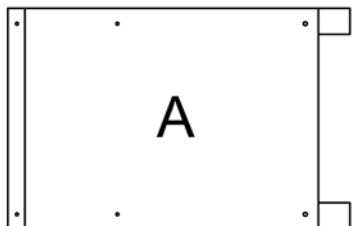

3017A-Side Panel Left 1pc  
3017B-Side Panel Right 1pc  
3017D-Drawer Back 1pc  
3017E-Top 1pc  
3017F-Drawer Side 2pcs

3017H-Drawer Front 1pc  
3017I-Drawer Bottom 1pc  
3017J-Back Panel 1pc  
3017K-Fixed Shelf 2pcs

**PARTS ARE USUALLY MARKED ON THE RAW EDGE.**

1

When first inserting camlocks, make sure they always point towards edge of board as indicated.

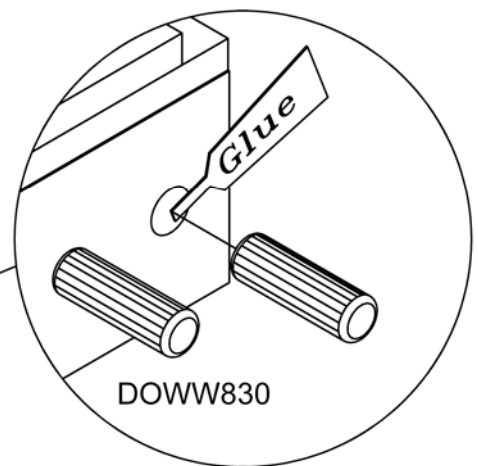
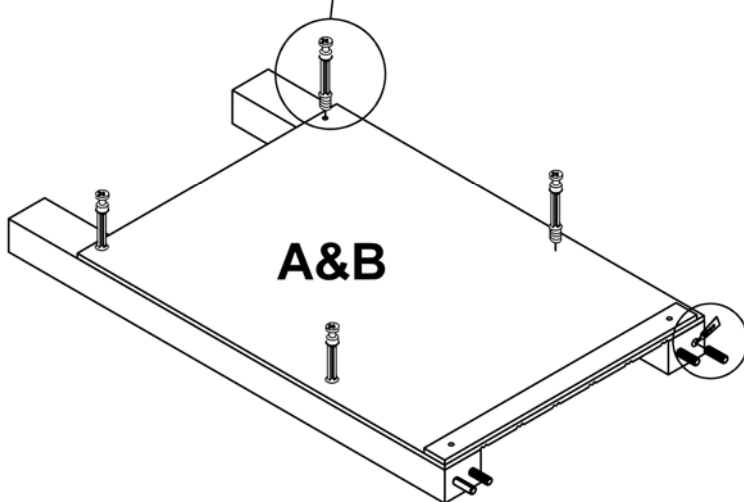
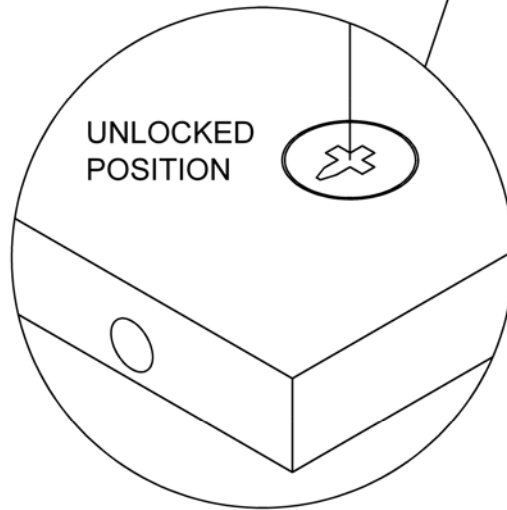
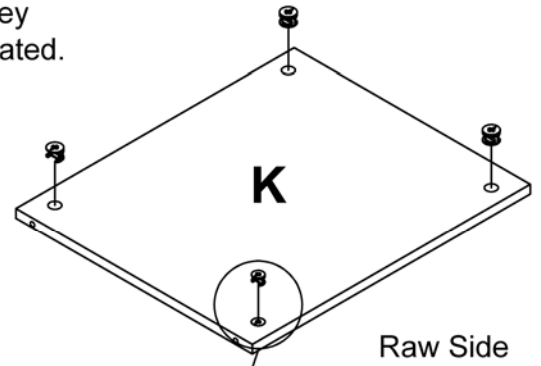
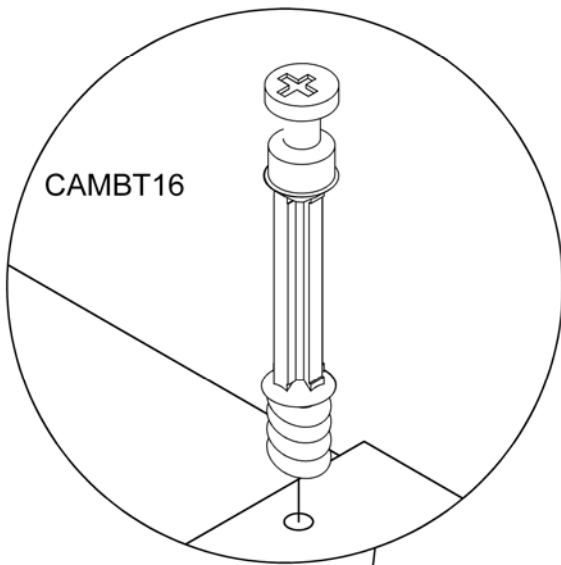

Insert wood dowels by tapping onto them with a hammer. Make sure they go in as far as possible. Wood dowels should not stick out more than 1/2"

**2**

Place parts (A, B, and K) with raw edges facing down. Align bolts in the sides (A and B) with the corresponding holes of part (K), bring them together without leaving gaps and lock the camlocks by turning them clockwise little over half a turn until full stop. When locked, arrow on camlock should point away from the edge as indicated.

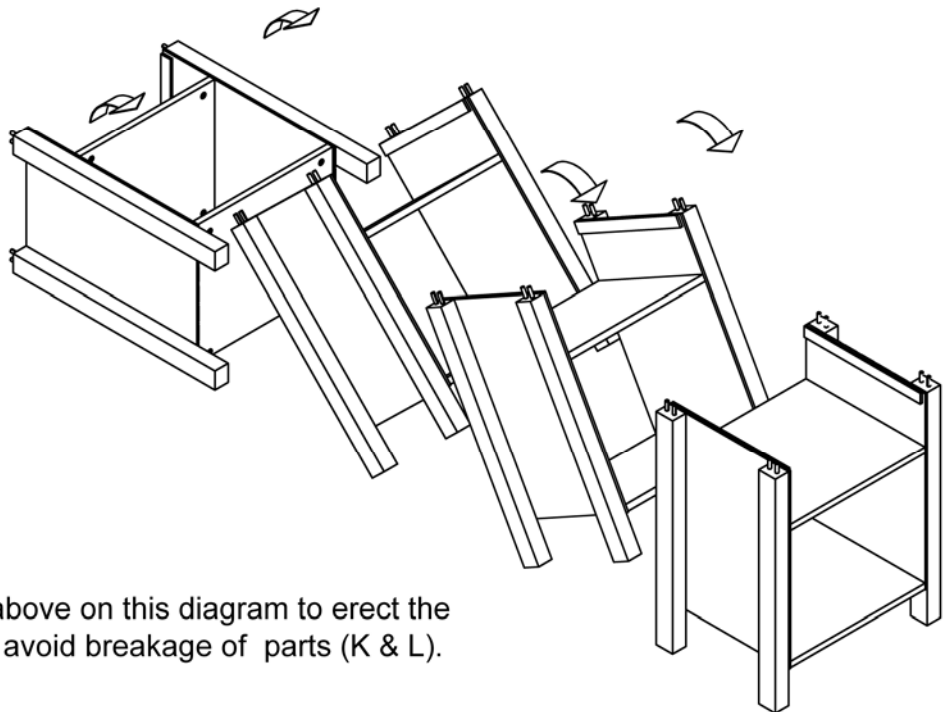
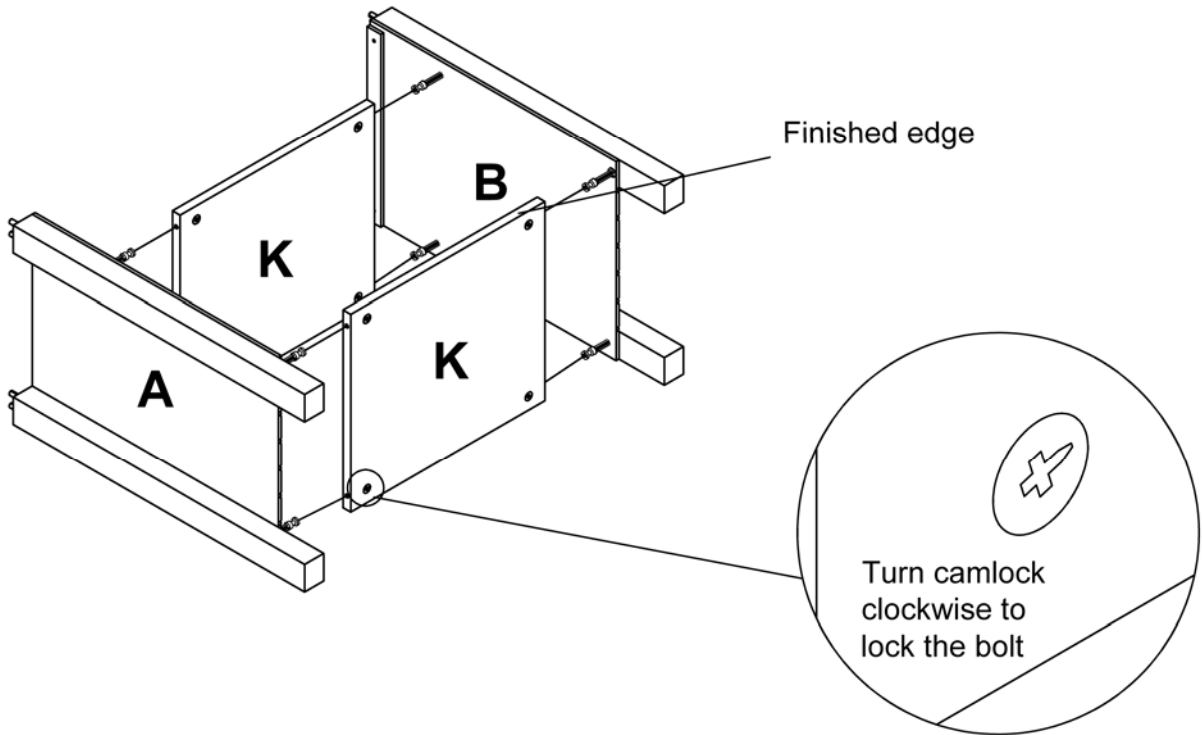

Please follow steps above on this diagram to erect the assembly in order to avoid breakage of parts (K & L).

**3**

Note: Make sure you align the raw edges of part (E) to parts (A and B) in the back when attaching. Lightly tap on the top piece (part E) onto the unit in order not to leave any gaps in between them. Be careful because you may not be able to undo this step once glue has set.

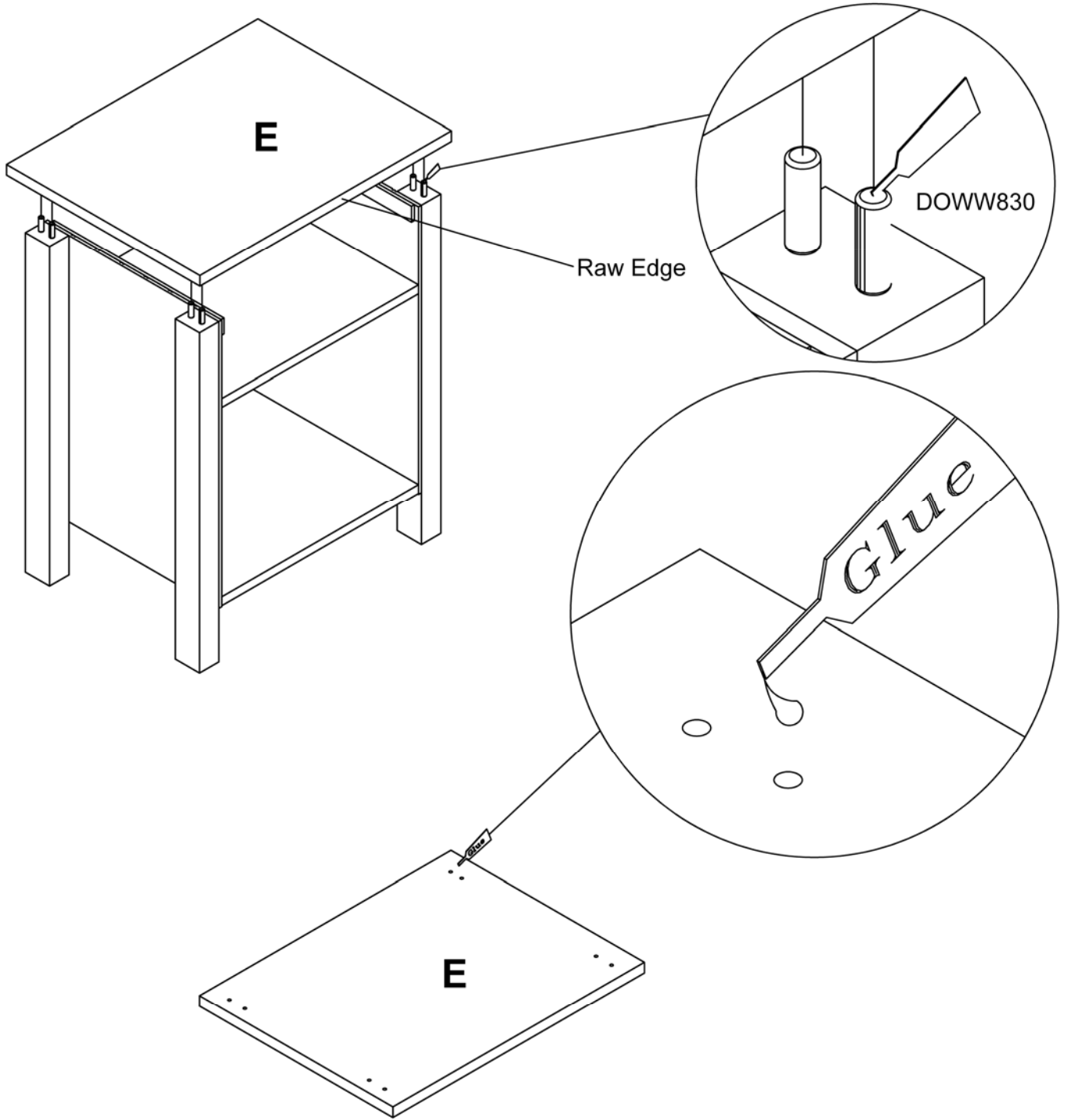

4

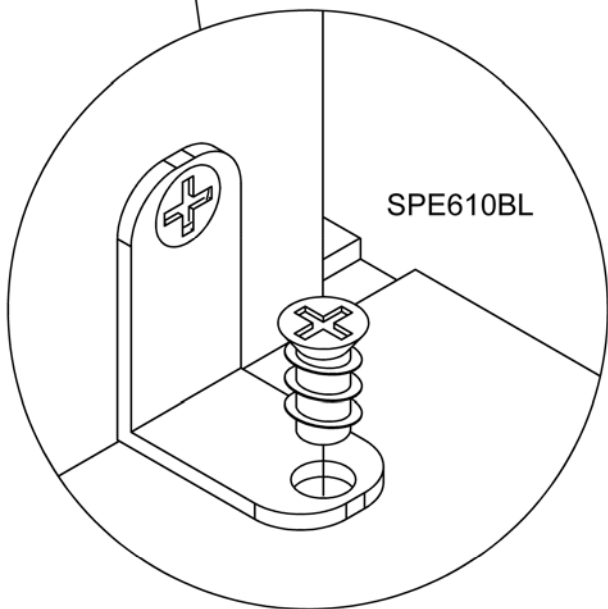
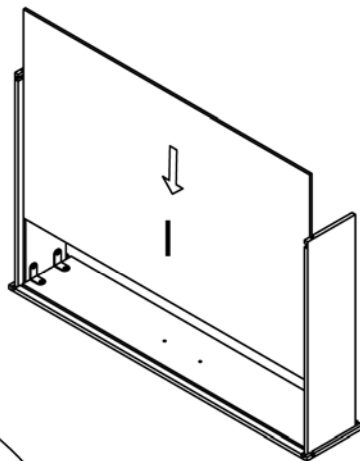
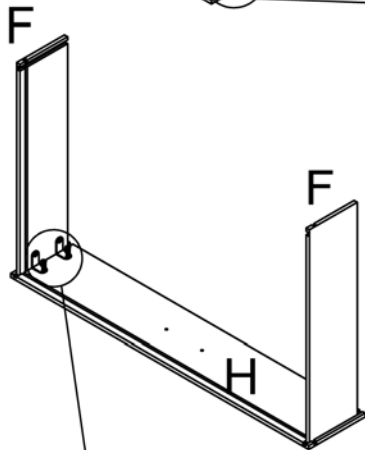
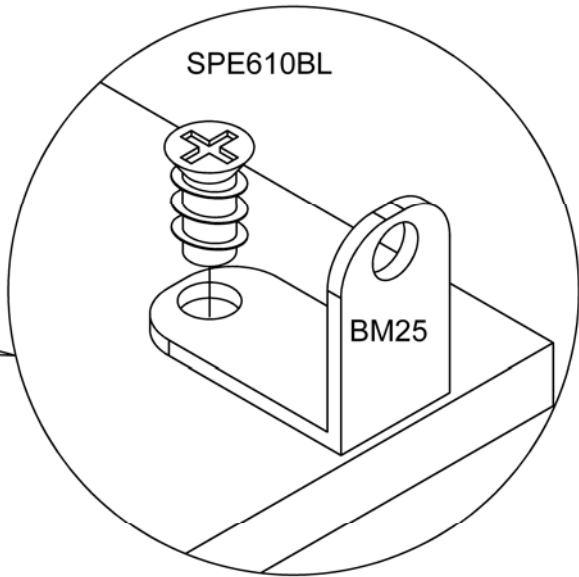
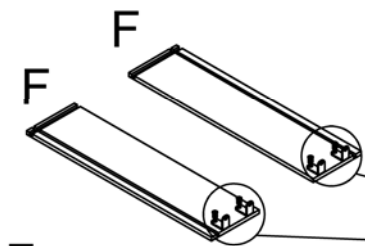

Note: Once parts (F) have been attached to part (H) with the euro screws, a total of four. Then slide in the bottom part of the drawer (Part I).

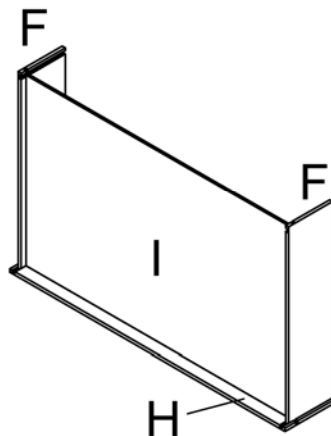

5

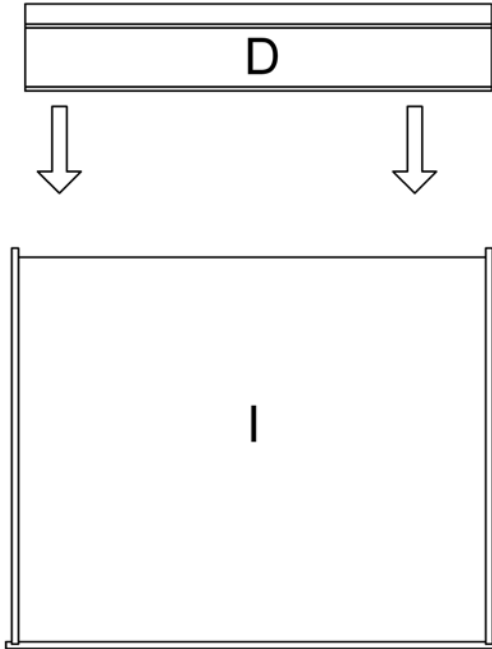

Note: Place (D) onto (in between) Drawer Sides (F).

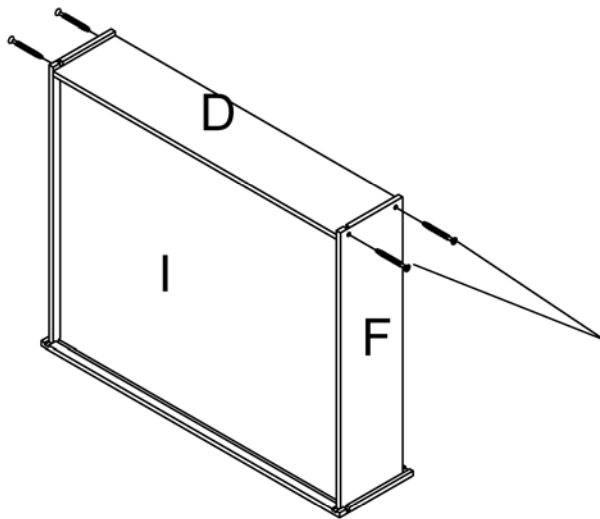

Note: Once part (D) is placed, fasten both parts with a total of four screws as shown below.

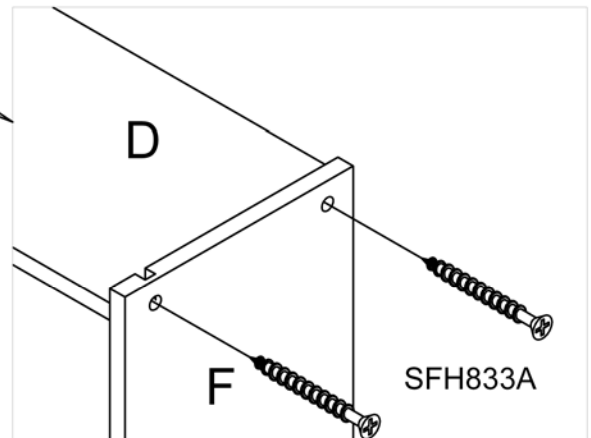

**6** Place the unit face down. Align the Back Panel (J) over the of the drawer opening. Make sure the assembly is square and leave equal amount of margin all around. Secure the panel by fastening 8 screws through the pre-drilled holes.

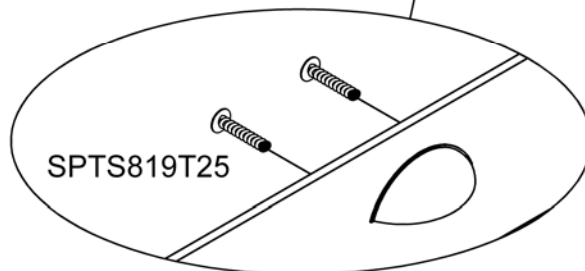
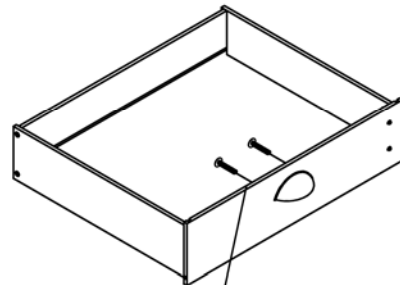
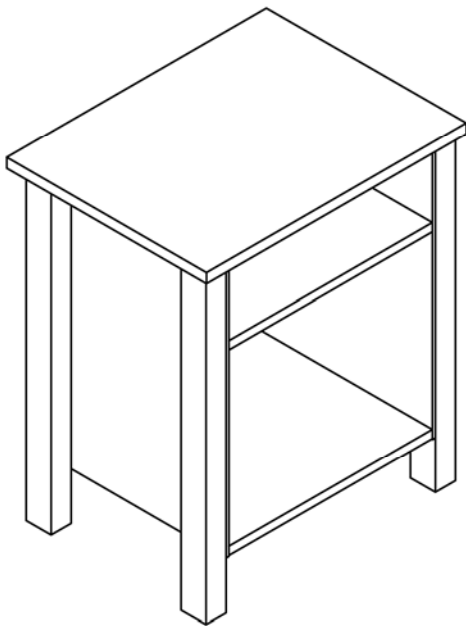
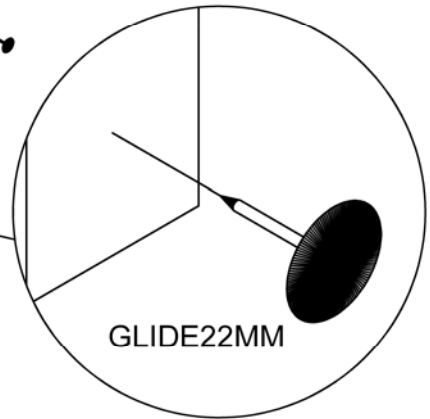
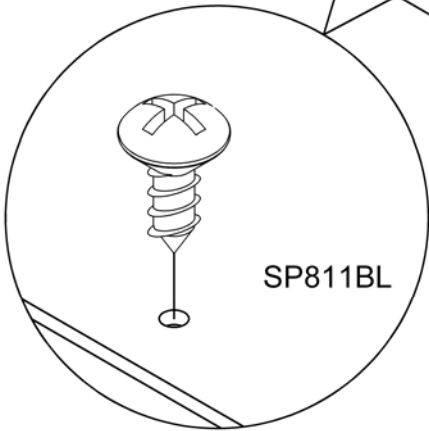
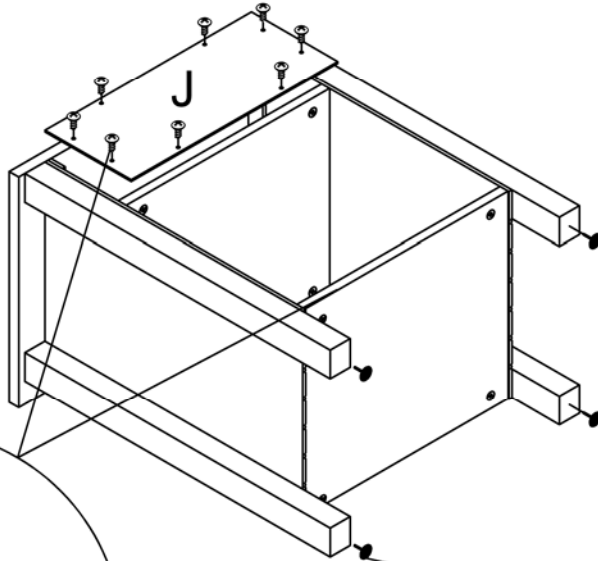

7

Note: Insert the drawer by following the diagram below.

