



IF PARTS ARE MISSING AND OR DEFECTIVE, IF INSTRUCTIONS ARE NOT CLEAR  
OR IF YOU ARE EXPERIENCING PROBLEMS ASSEMBLING OUR PRODUCT.

**BEFORE YOU RETURN THE PRODUCT TO THE STORE,  
PLEASE CALL US TOLL FREE FOR CUSTOMER SERVICE ASSISTANCE**

**(888) 777-8250**

**OR SEND US EMAIL AT**

**help@spartakent.com**

PLEASE HAVE ITEM NUMBER READY, AND A REPRESENTATIVE WILL GLADLY ASSIST YOU

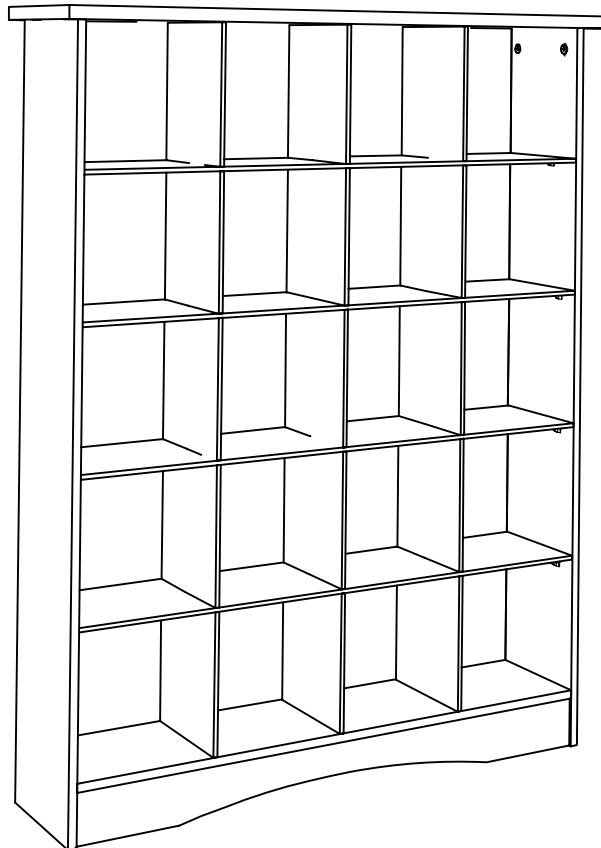

# PARTS IDENTIFICATION



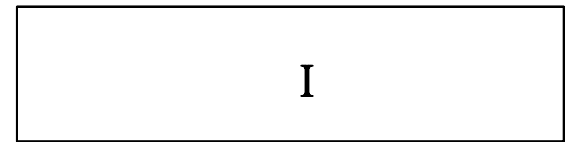
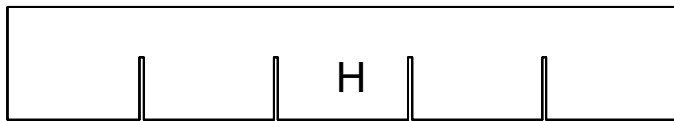
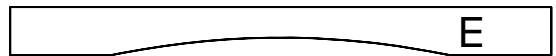
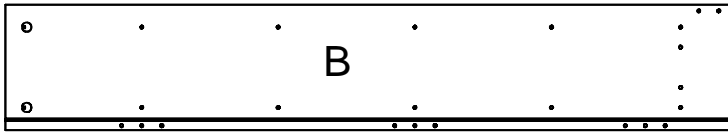
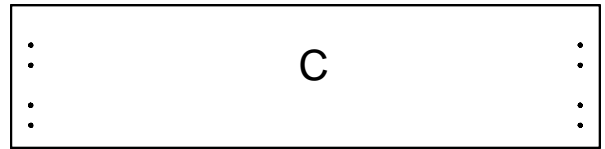
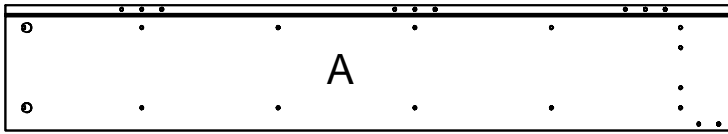

NOTE: FIRST MAKE SURE THAT YOU HAVE ALL OF THE PARTS LISTED ON THIS SHEET. IF YOU ARE MISSING ANY PIECE(S), DO NOT ASSEMBLE THE UNIT. INSTEAD, CALL OUR CUSTOMER SERVICE NUMBER AT: (888) 777-8250. WE WILL BE HAPPY TO ASSIST YOU.



2641A-Left Side 1pc  
 2641B-Right Side 1pc  
 2641C-Top 1pc  
 2641D-Bottom 1pc

2641E-Skirt 1pc  
 2641F-Back Rail 3pcs  
 2641G-Horizontal Divider 4pcs  
 2641H-Vertical Divider 3pcs  
 2641I-Back Panel 5pcs

**PARTS ARE USUALLY MARKED ON THE RAW EDGE**

HARDWARE	PART #	DESCRIPTION	QTY
	BP--5	SHELF SUPPORT	16
	DOWW525	WOOD DOWEL	24
	CAMLT12	CAMLOCK	14
	CAMBT12	BOLT	14

1

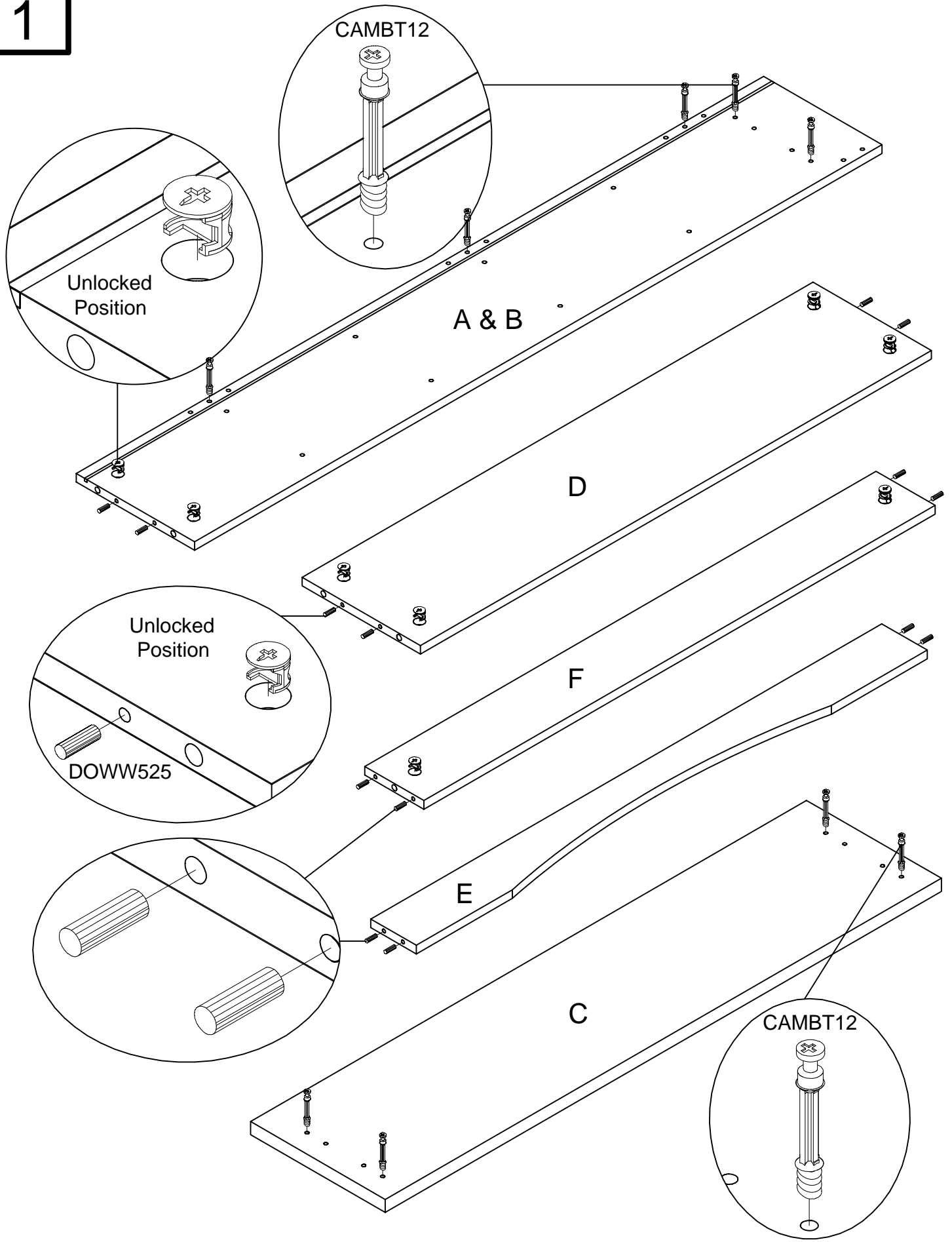

2

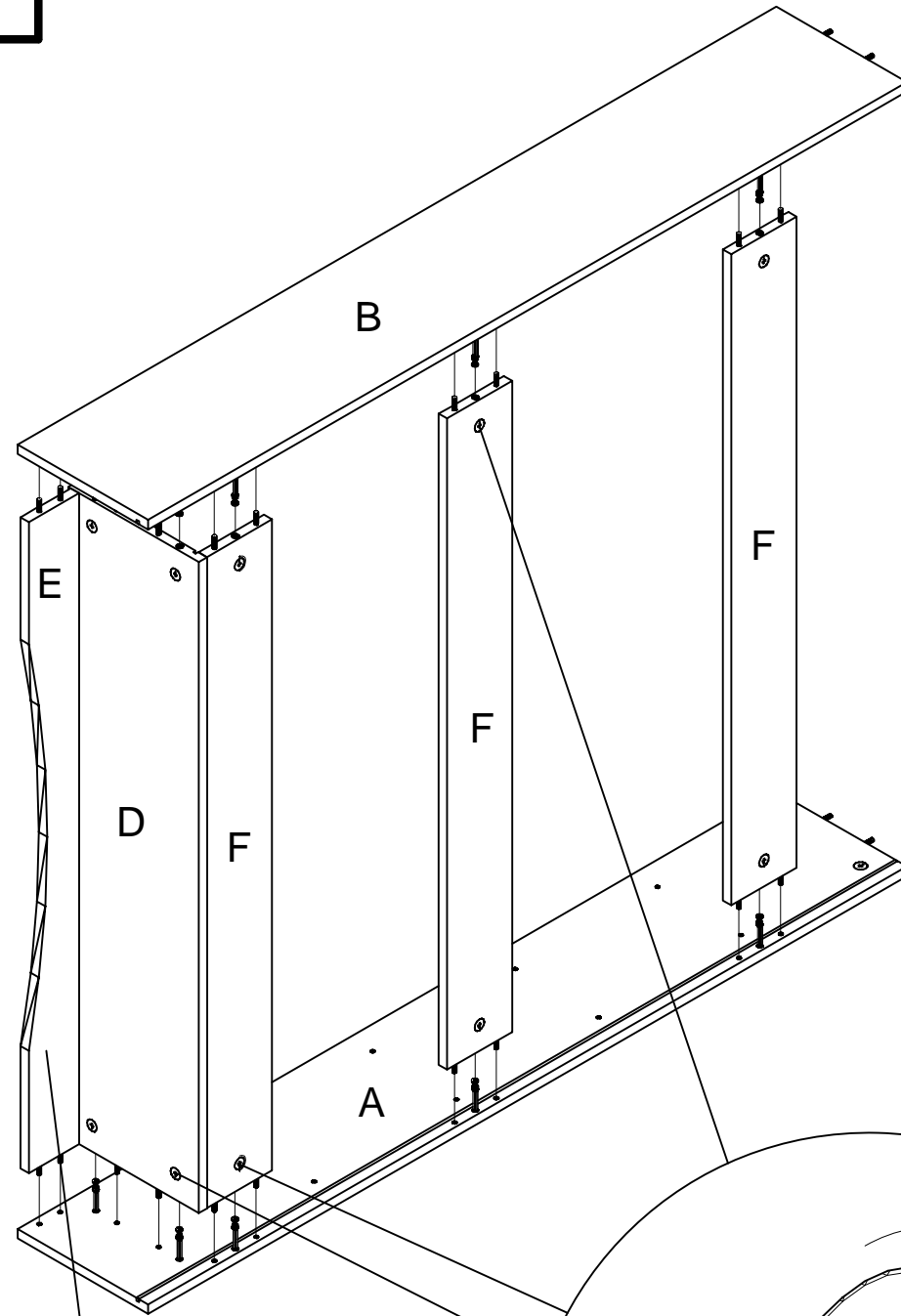

UNFINISHED SIDE

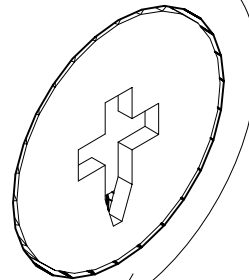

Turn camlocks clockwise until full stop on parts D and F (slightly over  $\frac{1}{2}$  a turn to lock the bolt)

3

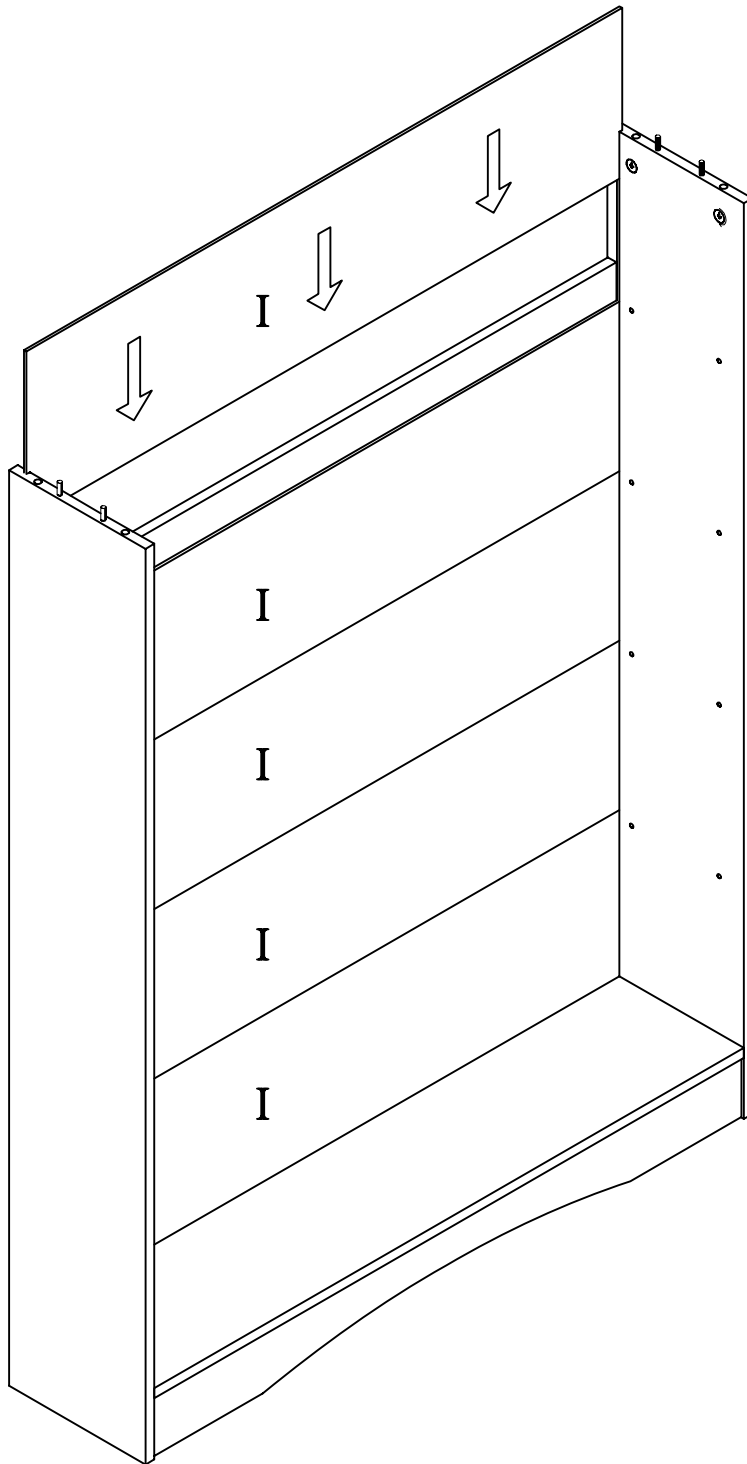

4

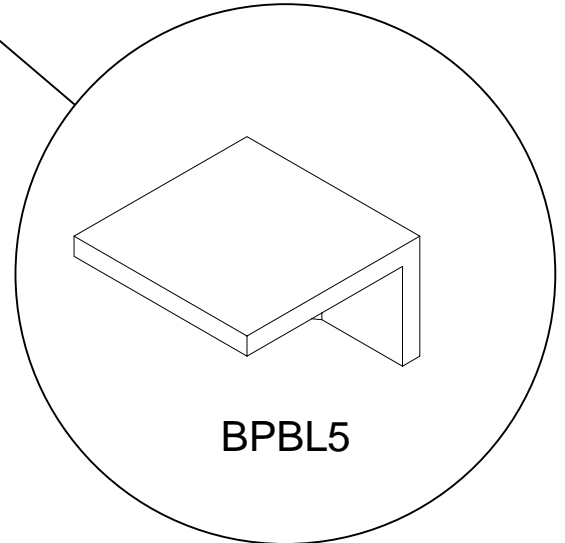
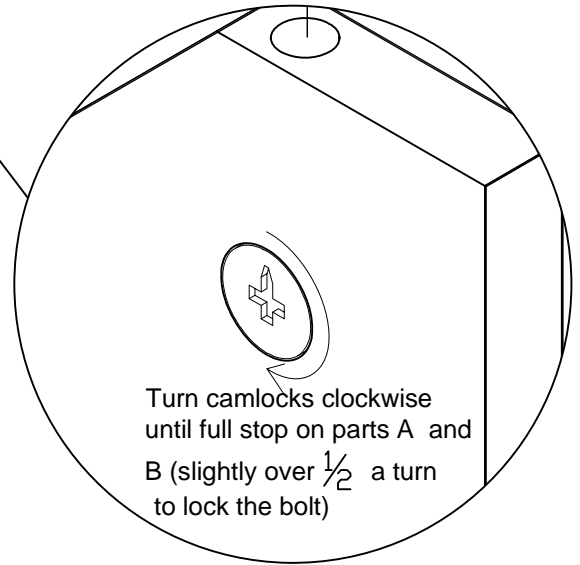
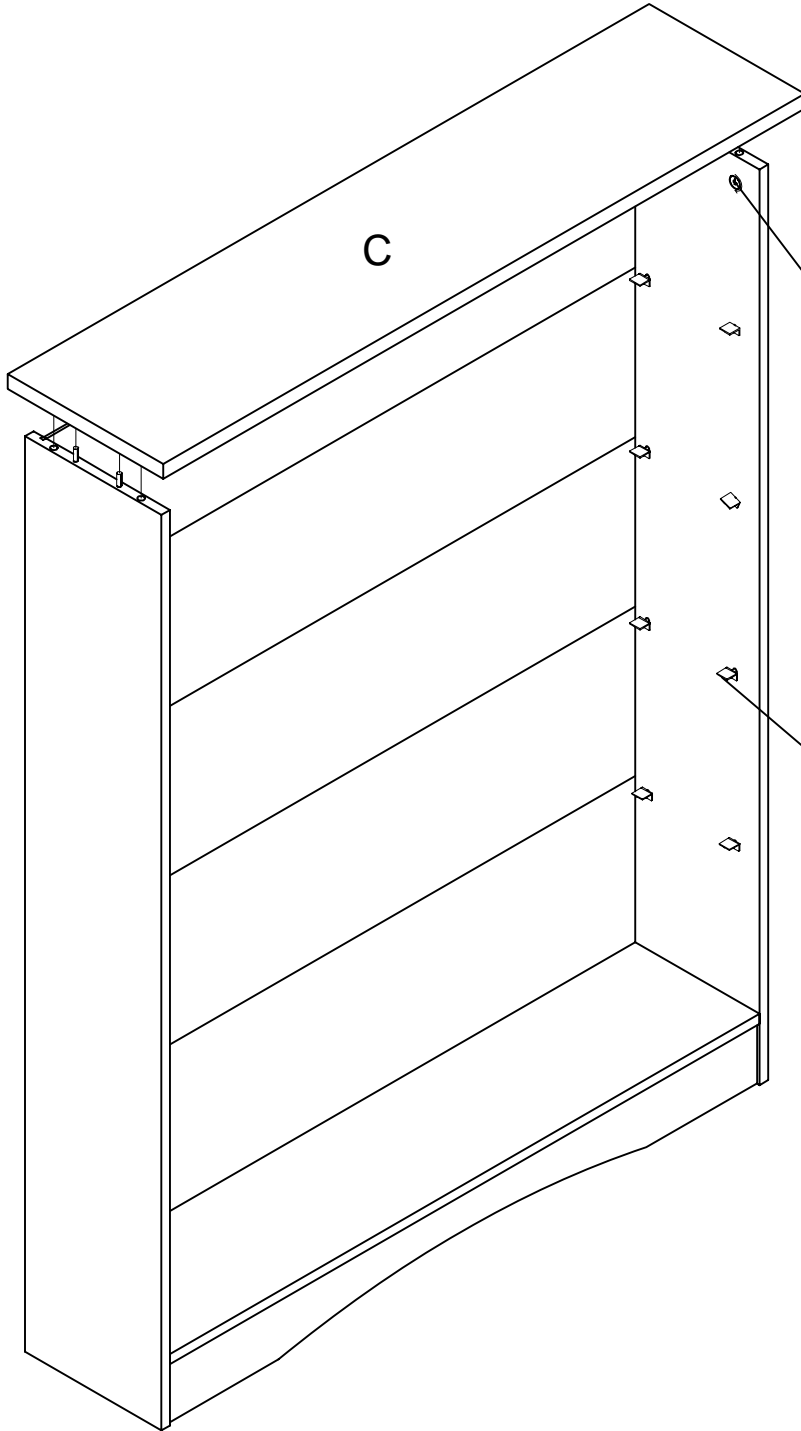

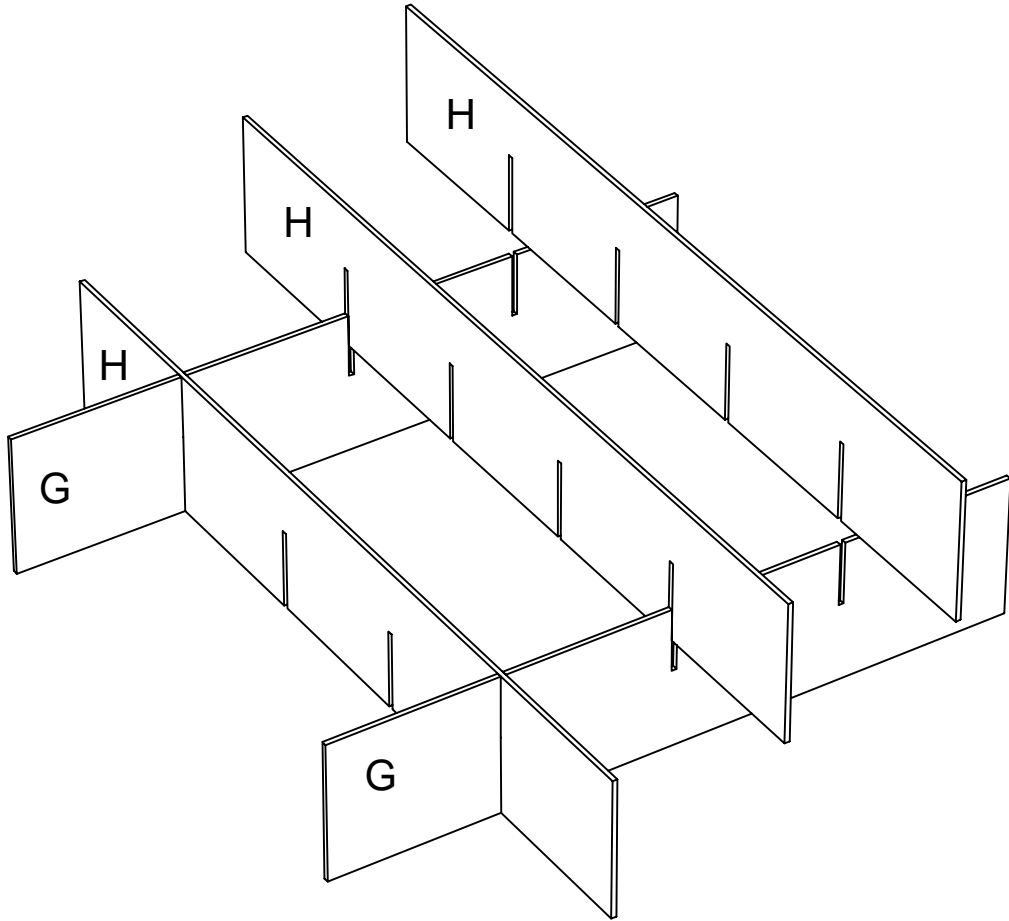

Turn the grid upside down to connect the middle dividers

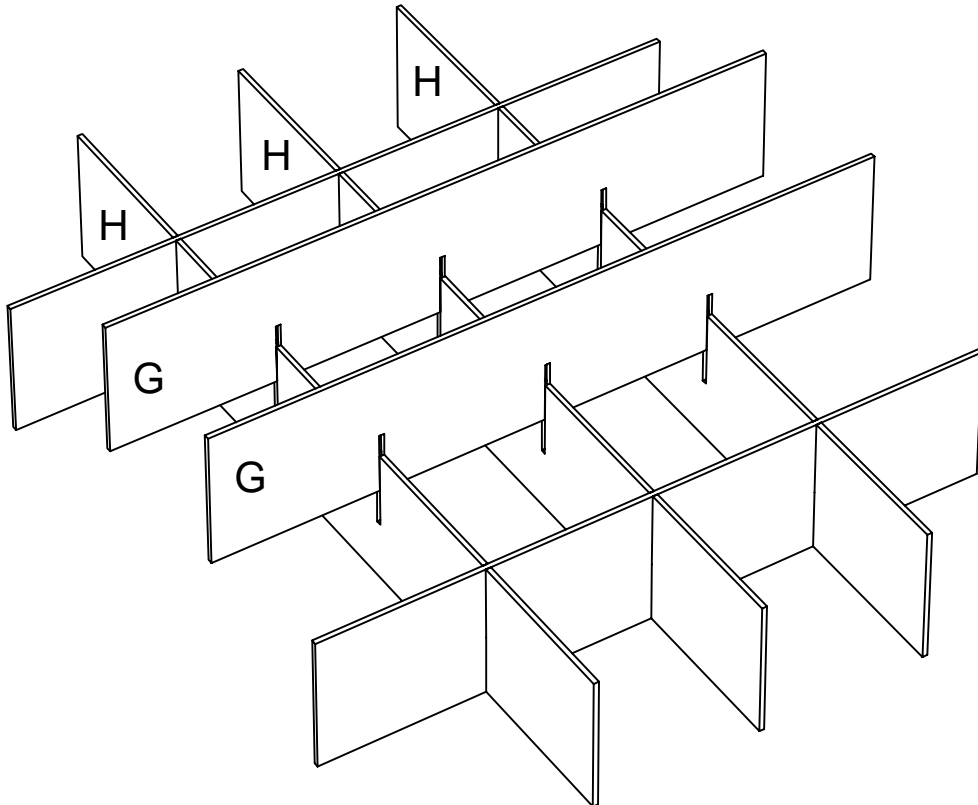

6

Make sure all Plastic Shelf Support are sitting in straight and then insert the grid inside of cabinet with finished edges facing out. Should you have difficulty getting pass Plastic Shelf Supports -then just lift slightly ends of horizontal dividers G.

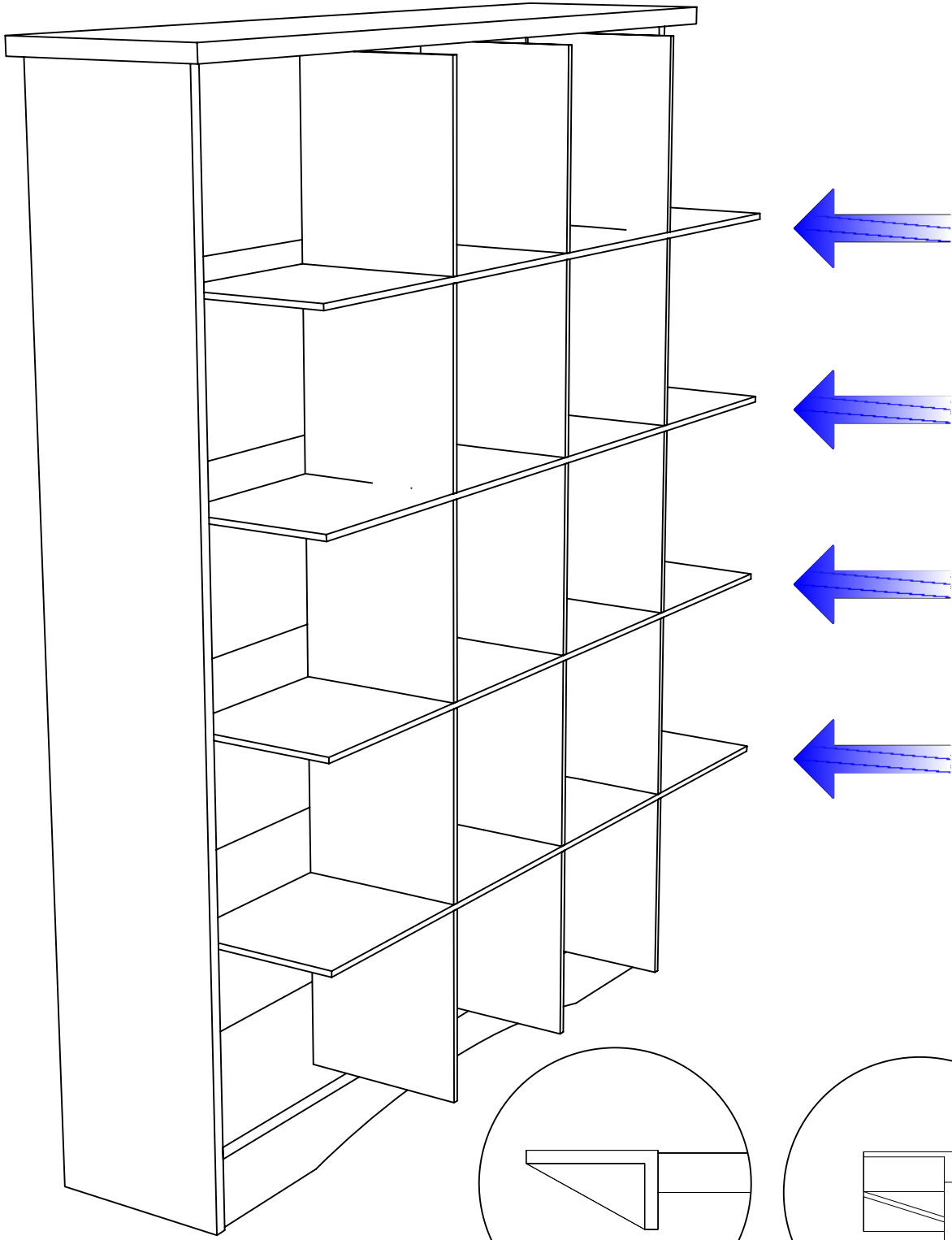

YES

NO