















5

Note: Fasten the angle with the euro screw as shown to the right.

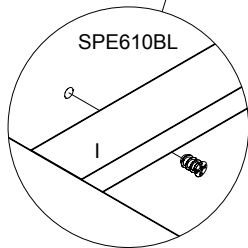
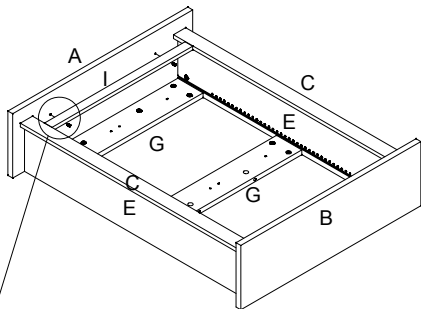
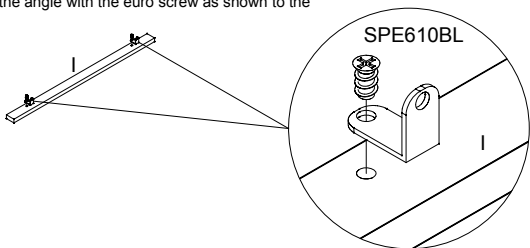

Note: Next, attach (Part I) to the unit. Shown to the left.

6

Please follow steps above on this diagram to erect the assembly in order to avoid breakage of stretchers, (G).

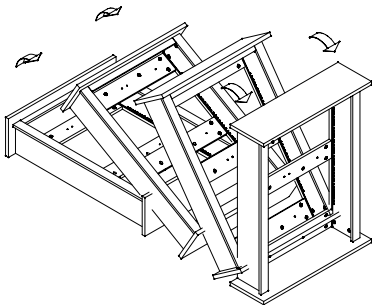

Install Back Panels as shown, with unmarked edges facing down and blue or red marked being atop. Make sure the Blue is on the left side and Red is on the right side of each section. Otherwise you will have problem with leveling of the shelves, they will sag in the middle.

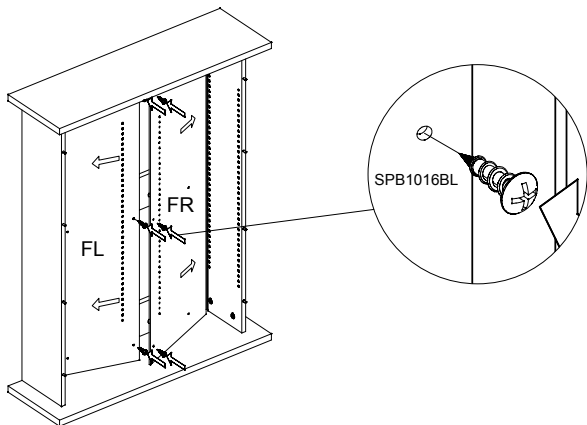

07

At this stage you are ready to screw the unit onto the wall. For the most secure installation drive the screws into the wall studs. The predrilled holes on the horizontal wall mounting rail are spaced on 8" centers. Hence, if studs in your wall are on standard 16" spacing you will be able to fasten the rail. The same applies for 12" and 24" spaced studs. Use a level to assure the unit is parallel with the floor. Otherwise the unit might look crooked. Also keep in mind that the top of the unit will be about 4" higher from where you have secured the wall mounting rail.

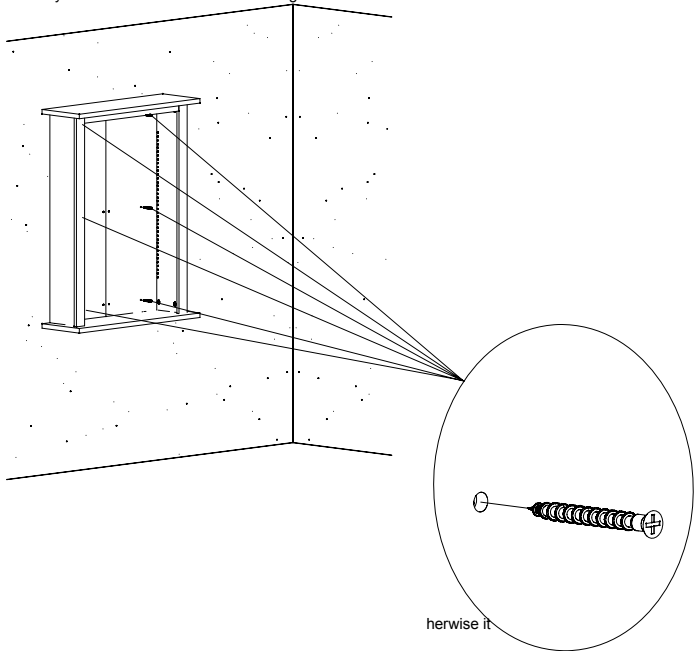

08

Do not tap with hammer onto shelf supports, instead twist them when inserting in. You will be using six shelf supports per shelf, two on each side and two in the back.

Install shelves at desired locations. Use a case of CD or DVD as a template to locate positions for the shelves. Start from the bottom. If you skip a hole or mix in one section with CD or DVD/VHS cases, you may end up with some unused space at the top. In other words, to get the maximum capacity, don't skip any holes or mix different kinds of media in one section.

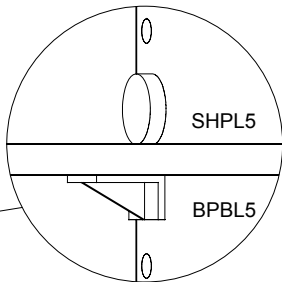
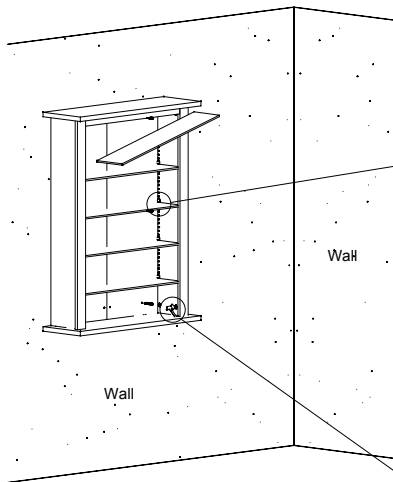

To prevent shelves from sagging, lock the back corners of them from above with two round Shelf Locks.

