



IF PARTS ARE MISSING AND OR DEFECTIVE, IF INSTRUCTIONS ARE NOT CLEAR
OR IF YOU ARE EXPERIENCING PROBLEMS ASSEMBLING OUR PRODUCT.

**BEFORE YOU RETURN THE PRODUCT TO THE STORE,
PLEASE CALL US TOLL FREE FOR CUSTOMER SERVICE ASSISTANCE**

(888) 777-8250

OR SEND US EMAIL AT

help@spartakent.com

PLEASE HAVE ITEM NUMBER READY, AND A REPRESENTATIVE WILL GLADLY ASSIST YOU

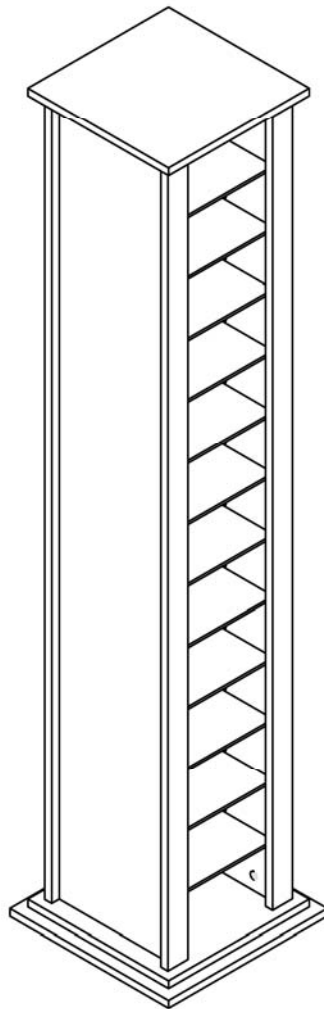

HARDWARE	PART #	DESCRIPTION	QTY
	BPXX5	SHELF SUPPORT	96
	DOWW525	WOOD DOWEL	44
	TRNTPL	SWIVEL PLATE	1
	TRNTSC	SWIVEL BOLT	1
	TRNTIN	BUSHING	1
	CAMLT12	CAMLOCK	8
	CAMBT16	BOLT	8
	BM25-PNXX	BRACKET ANGLE	7
	SPE610BL	EURO SCREW	7
	GLUEWD	WOOD GLUE	1
	CCPZXX	CAMLOCK COVER CAP	8

TOOL REQUIRED



PHILLIPS SCREWDRIVER



HAMMER

PARTS IDENTIFICATION

NOTE: FIRST MAKE SURE THAT YOU HAVE ALL OF THE PARTS LISTED ON THIS SHEET. IF YOU ARE MISSING ANY PIECE(S), DO NOT ASSEMBLE THE UNIT. INSTEAD, CALL OUR CUSTOMER SERVICE NUMBER AT: (888) 777-8250. WE WILL BE HAPPY TO ASSIST YOU.

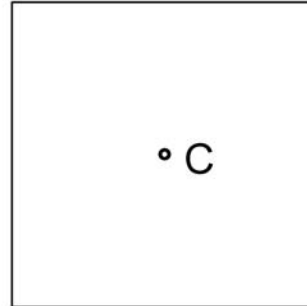
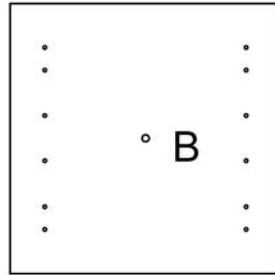
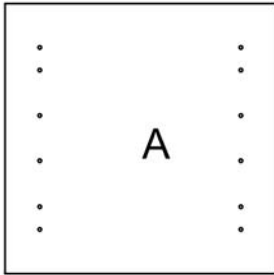

2021A-Top	1pc
2021B-Bottom	1pc
2021C-Base	1pc
2022D-Side	2pcs

2022E-Divider	1pc
2021F-Shelf	24pcs
2022G-Molding	4pcs

PARTS ARE USUALLY MARKED ON THE RAW EDGE

1

Apply one drop of glue in each hole with the dowel.
Make sure the dowels go in as far as possible. They
should stick out no more than 3/8 of an inch.

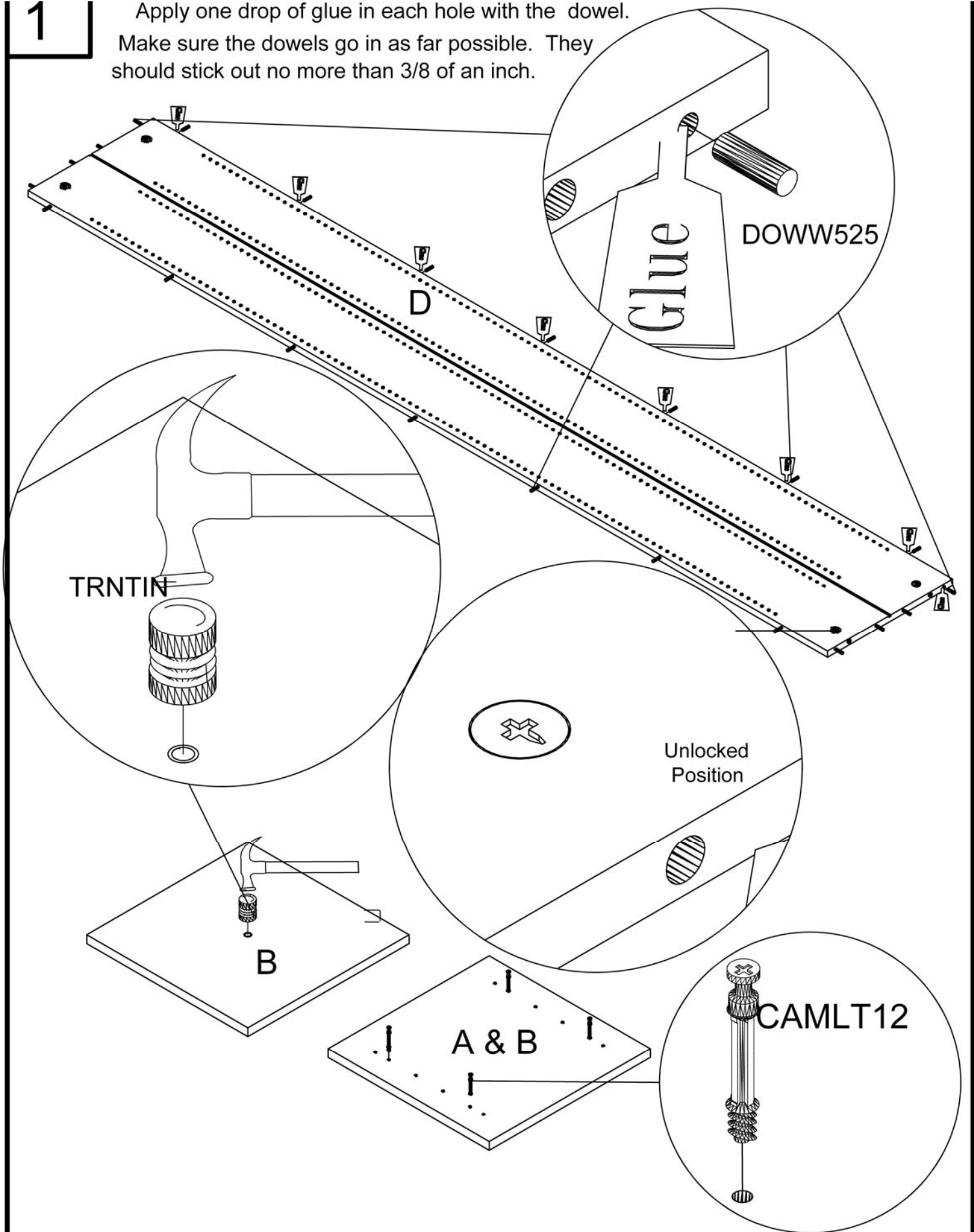

2

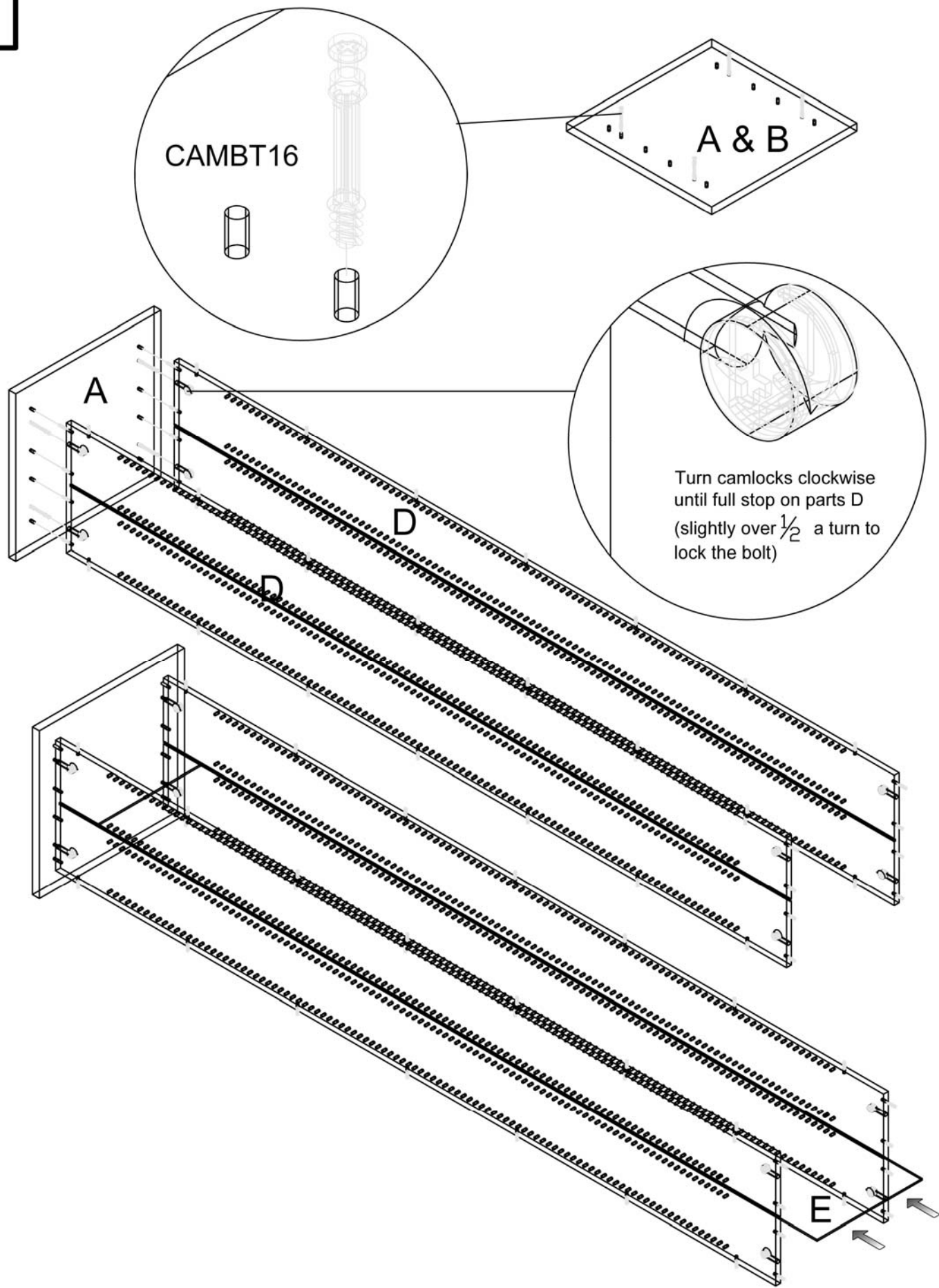

4

Bring the Top down onto the assembly and lock all camlocks.

Next apply glue onto the wood dowels and press Moldings G onto them.

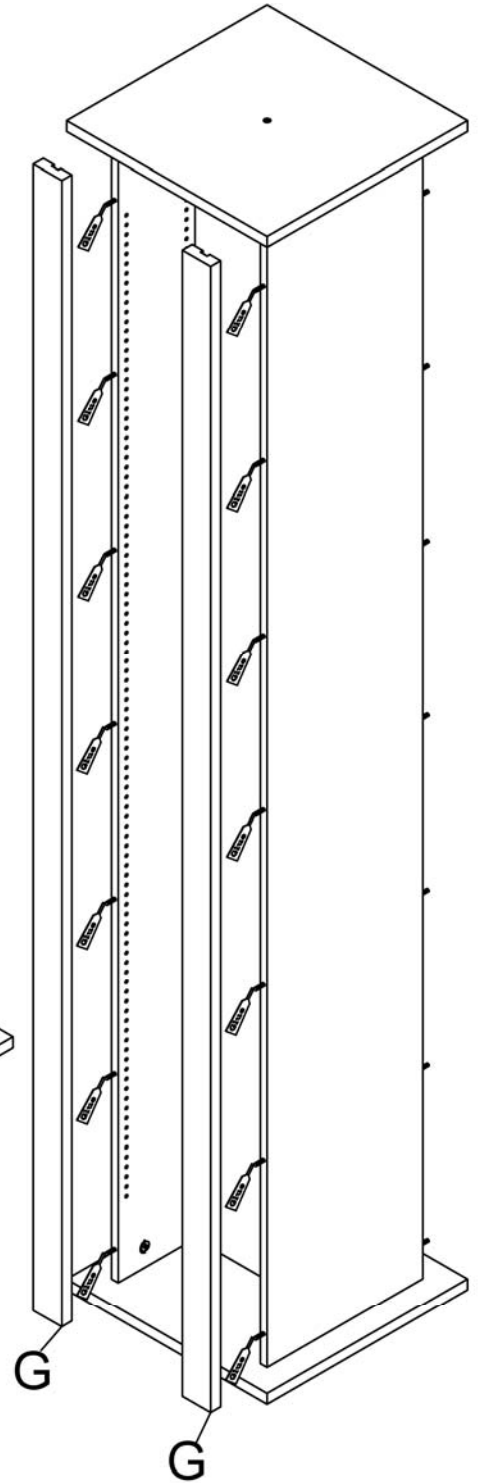
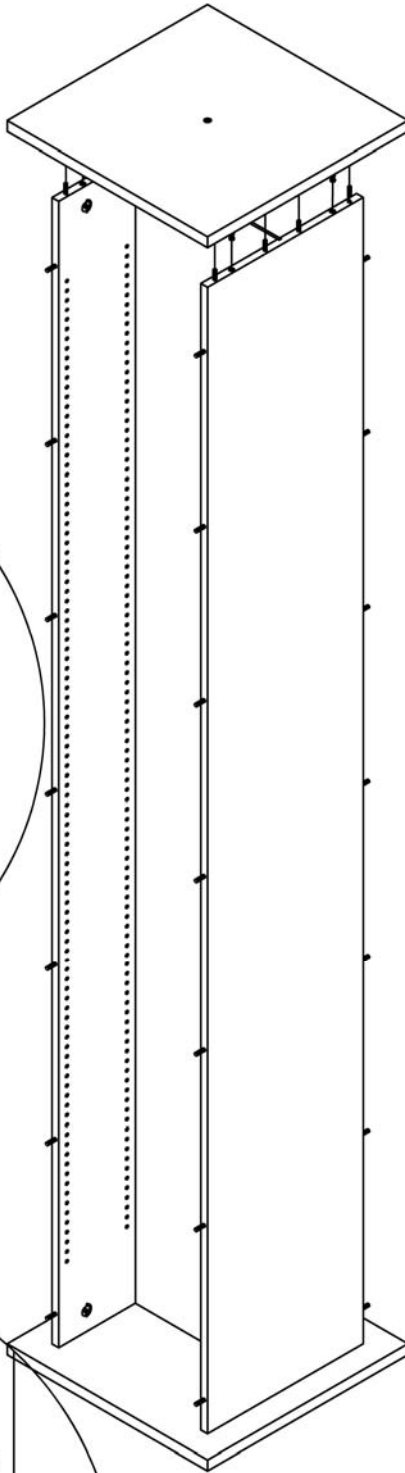
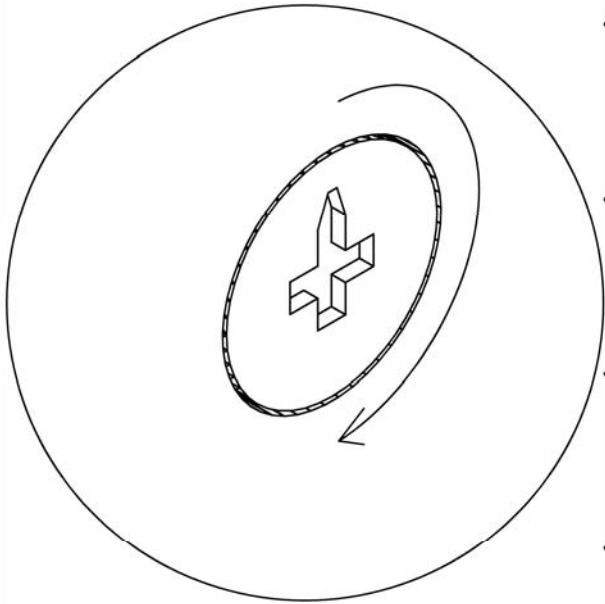

Repeat last step for opposite side

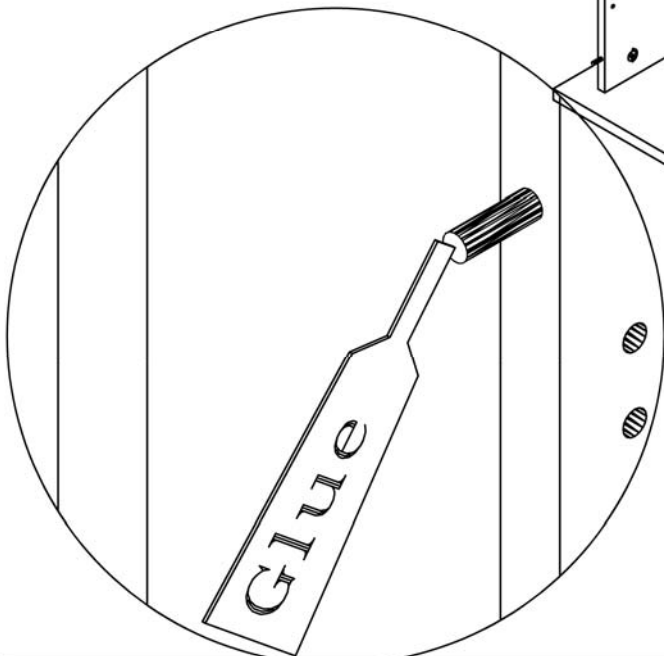

5

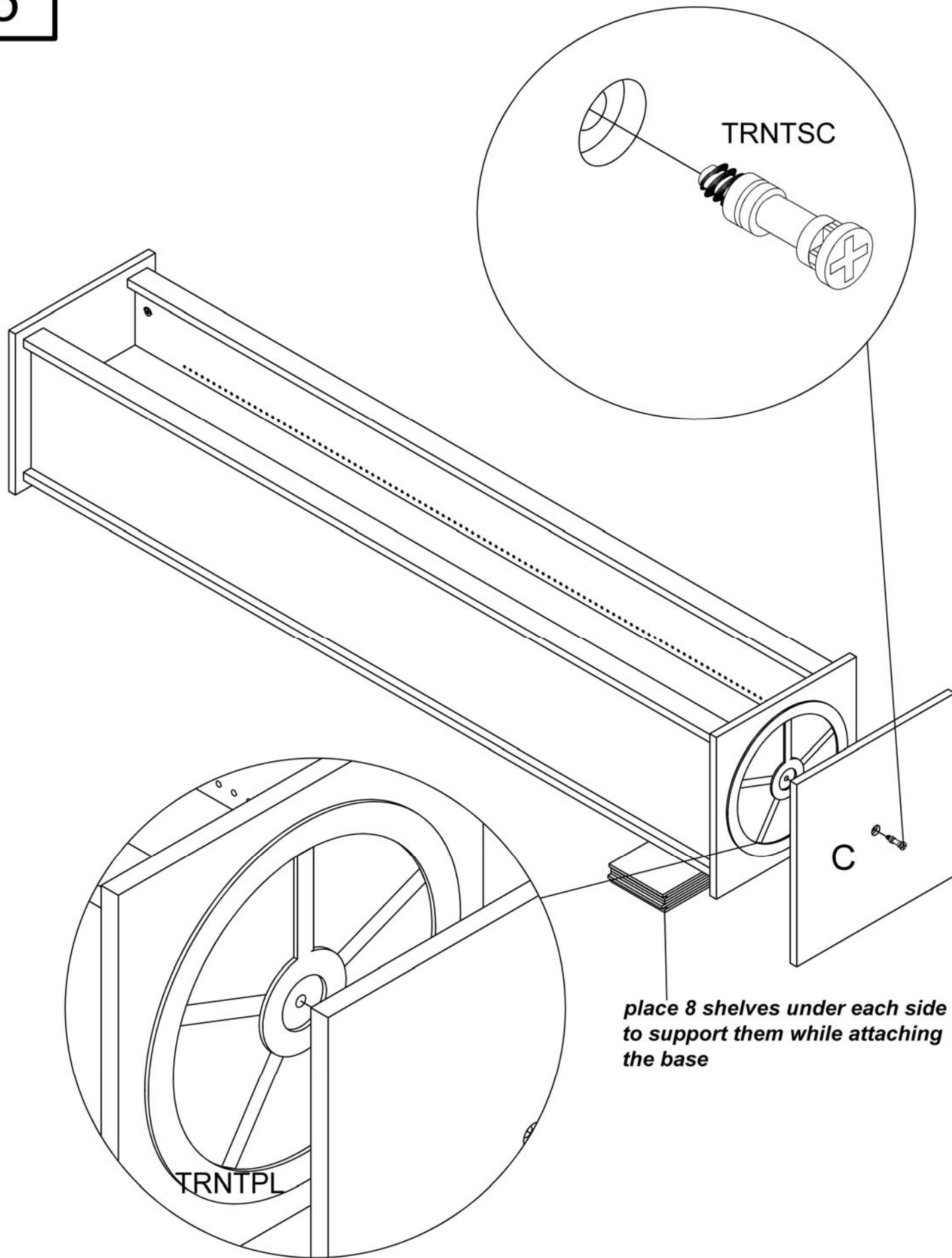

6

