



IF PARTS ARE MISSING AND OR DEFECTIVE, IF INSTRUCTIONS ARE NOT CLEAR  
OR IF YOU ARE EXPERIENCING PROBLEMS ASSEMBLING OUR PRODUCT.

**BEFORE YOU RETURN THE PRODUCT TO THE STORE,  
PLEASE CALL US TOLL FREE FOR CUSTOMER SERVICE ASSISTANCE**

**(888) 777-8250**

**OR SEND US EMAIL AT**

**[help@spartakent.com](mailto:help@spartakent.com)**

PLEASE HAVE ITEM NUMBER READY, AND A REPRESENTATIVE WILL GLADLY ASSIST YOU

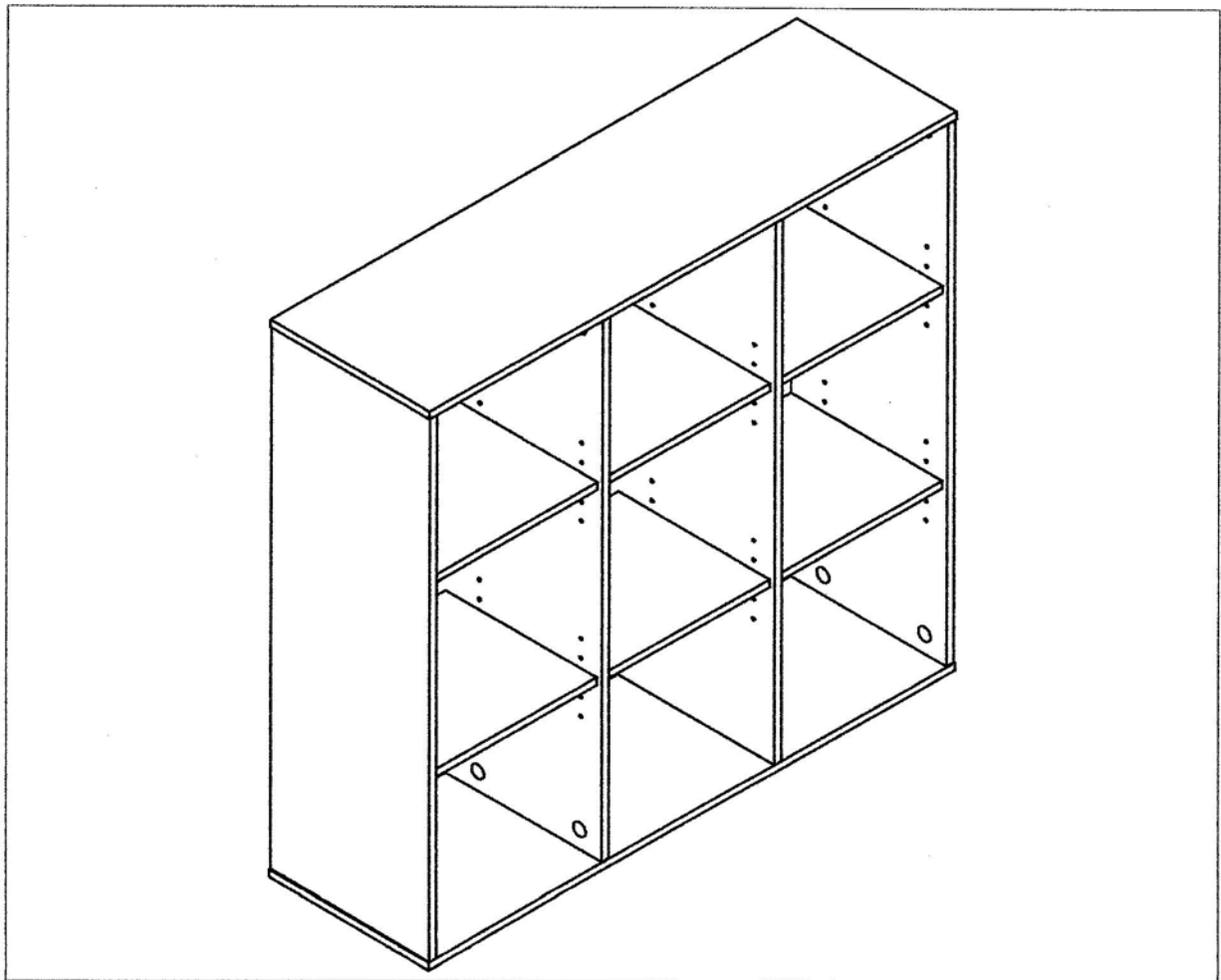

# PARTS IDENTIFICATION

NOTE: FIRST MAKE SURE THAT YOU HAVE ALL OF THE PARTS LISTED ON THIS SHEET. IF YOU ARE MISSING ANY PIECE(S), DO NOT ASSEMBLE THE UNIT. INSTEAD, CALL OUR CUSTOMER SERVICE NUMBER AT: (888) 777-8250. WE WILL BE HAPPY TO ASSIST YOU.

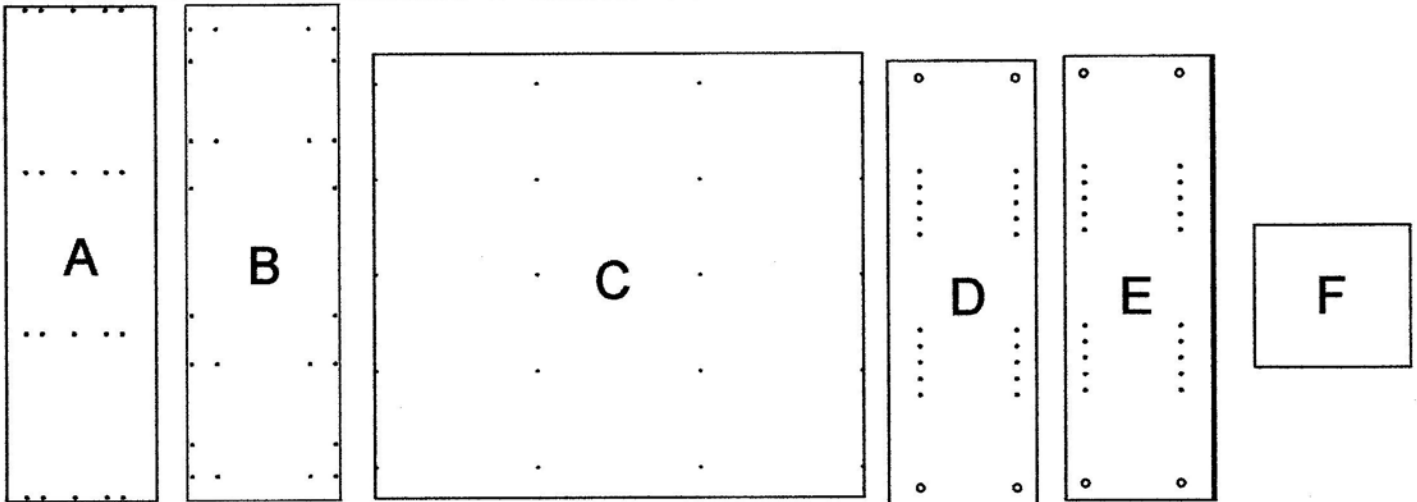

1143A-Bottom

1pc

1143D-Dividers

2pcs

1143B-Top

1pc

1143E-Sides

2pcs









1143C-Back Panel

1pc

1143F-Shelf

6pcs

**PARTS ARE USUALLY MARKED ON THE RAW EDGE.**

HARDWARE	PART #	DESCRIPTION	QTY
	CAMLT12	CAMLOCK	16
	CAMBT12	BOLT	16
	DOWW525	WOOD DOWEL	24
	CCPZBL	CAMLOCK COVER CAP	16
	BPXX54	SHELF SUPPORT	24
	NAIL1734X	NAIL	10
	GLUEWD	GLUE	1
	SPB1025BL	#10 x 1" PAN HEAD SCREW	8

**TOOL REQUIRED**

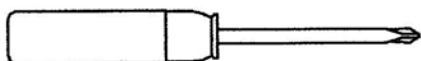

PHILLIPS SCREWDRIVER

1

Note: Screw the bolts on parts (A & B) as shown at the bottom. Next, insert the wood dowels in the center three holes on the ends for both parts of (D and E).

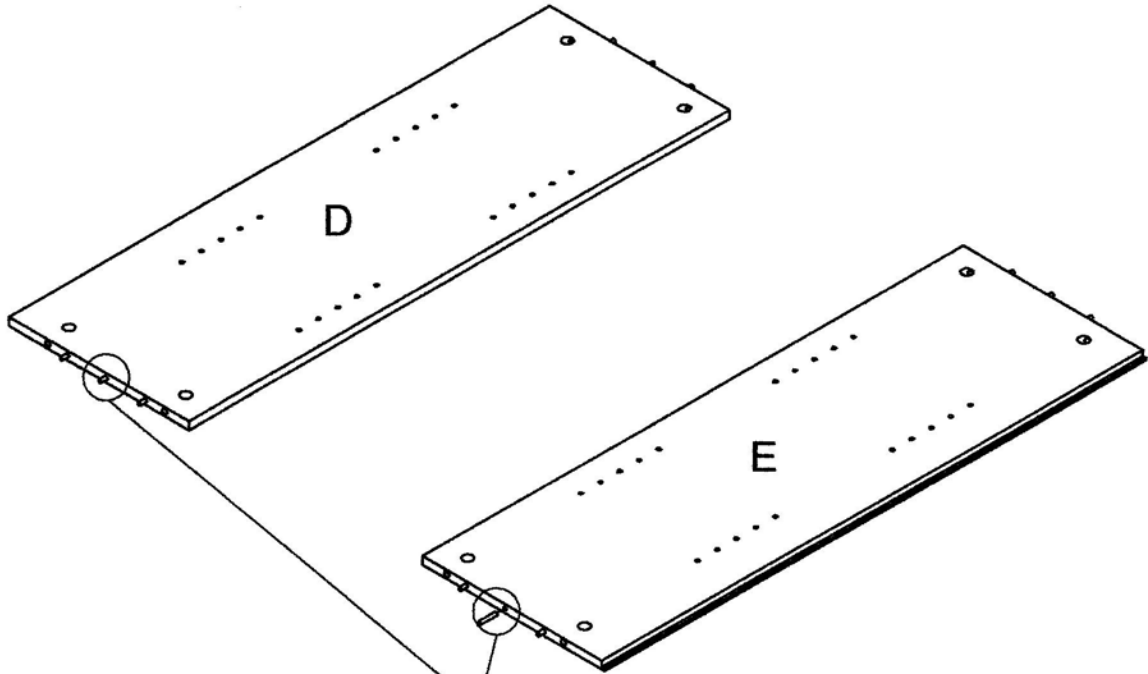

CAMBT12

DOWW525

Note: The 8 holes on Part (B), are for use only when you want to assemble the workstation.

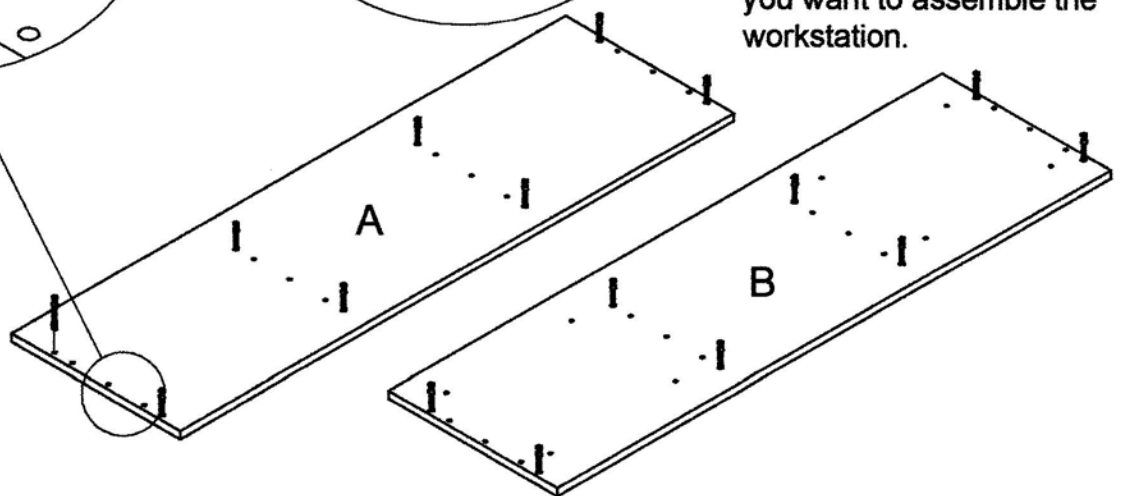

2

Note: When placing all 4 camlocks on both parts of (D and E) a total of 16 camlocks all together, make sure the arrow on the camlocks are facing towards the edge of the part as shown to the bottom.

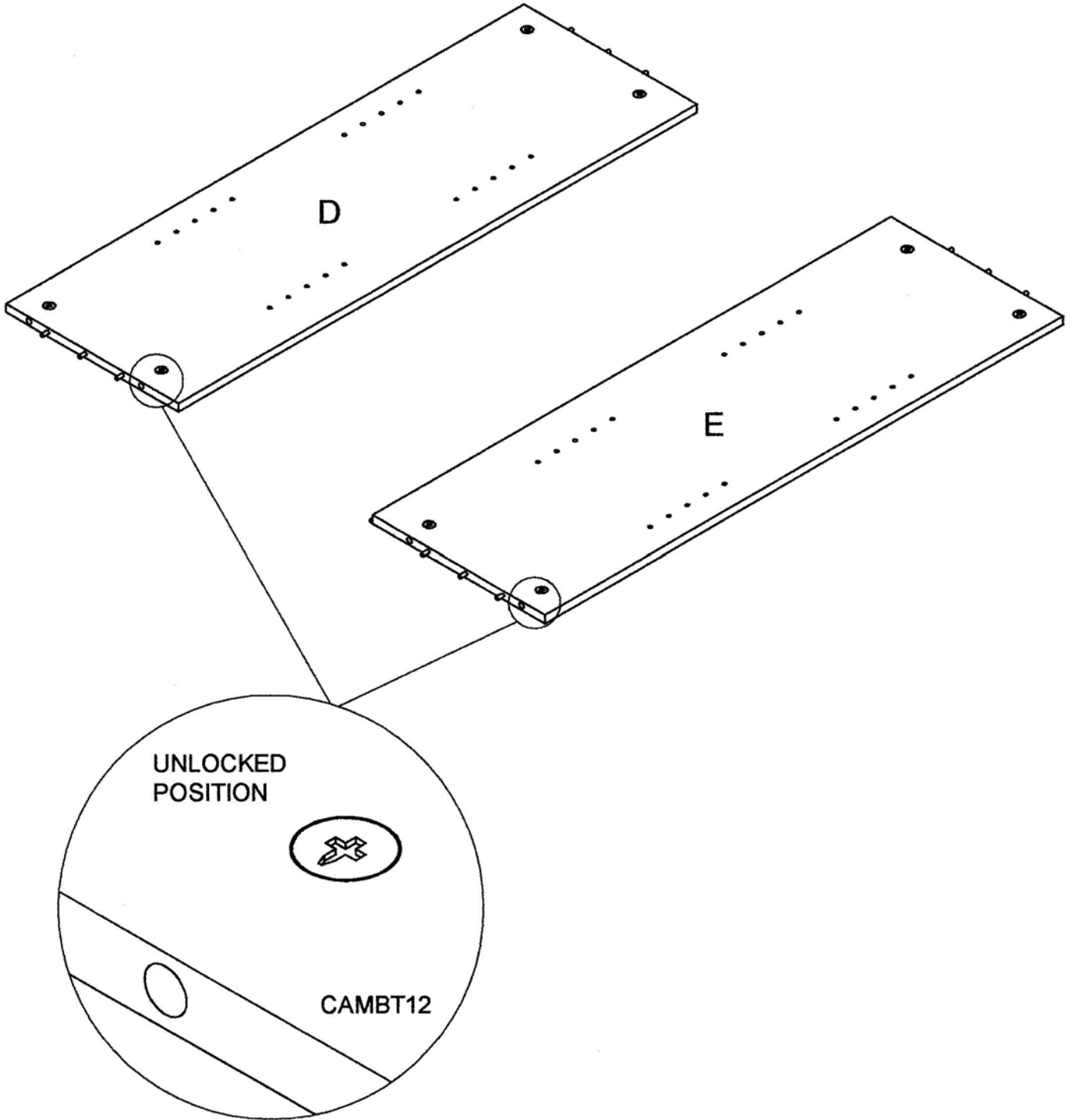

3

Align the back sides

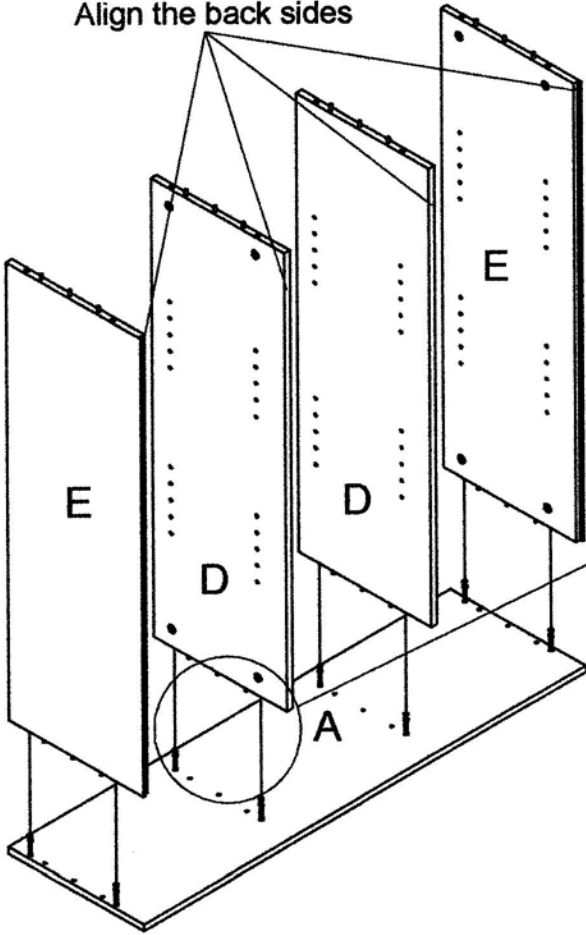

Note: Lay part (A) on the its side and attach parts (D and E) as shown to the left.

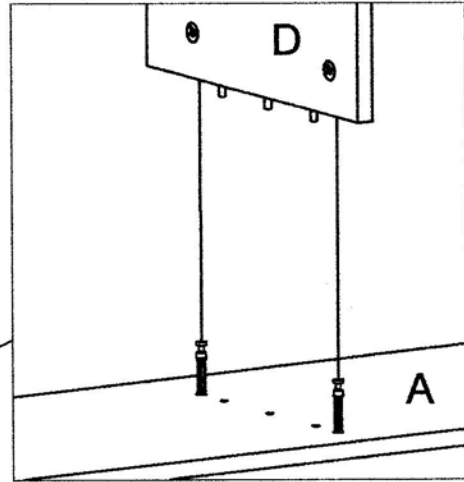

Turn the camlocks a little over half a turn clockwise, until you come to a full stop.

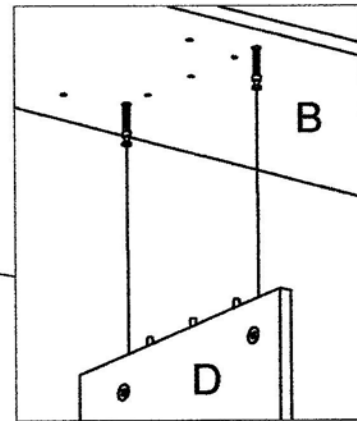
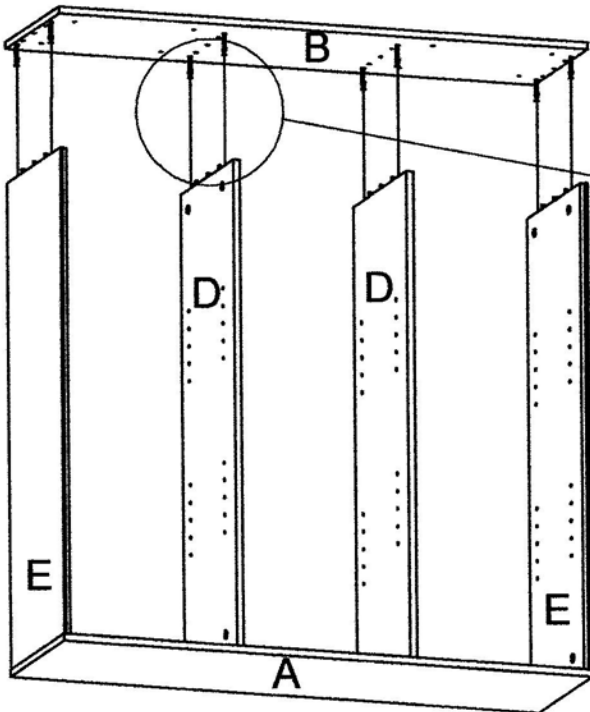

Note: Then, attach the top piece, part (B) as shown to the left.

4

Note: Lay the unit on its front so that the raw side of the edges are facing up. Apply glue to parts (E) only within the dado area (recessed surface) as shown below.

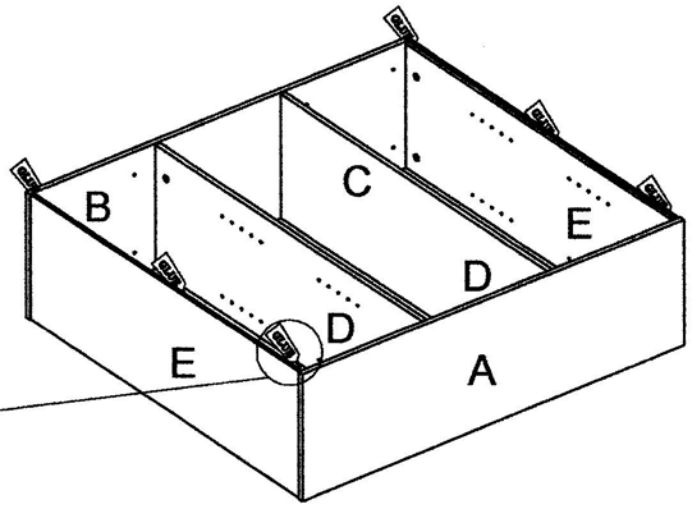
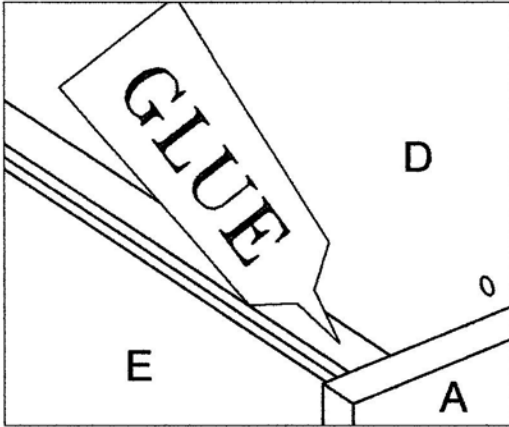

Note: Then, place part (C) on the frame of the unit and with 10 nails, nail through the pre-drilled holes as shown at the left

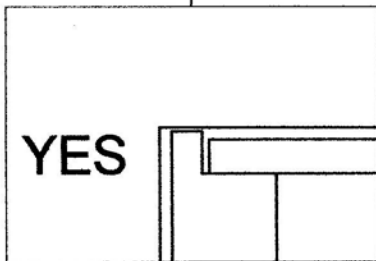
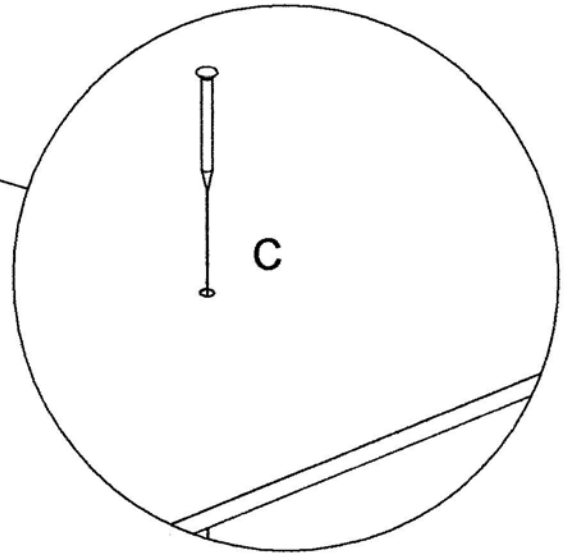
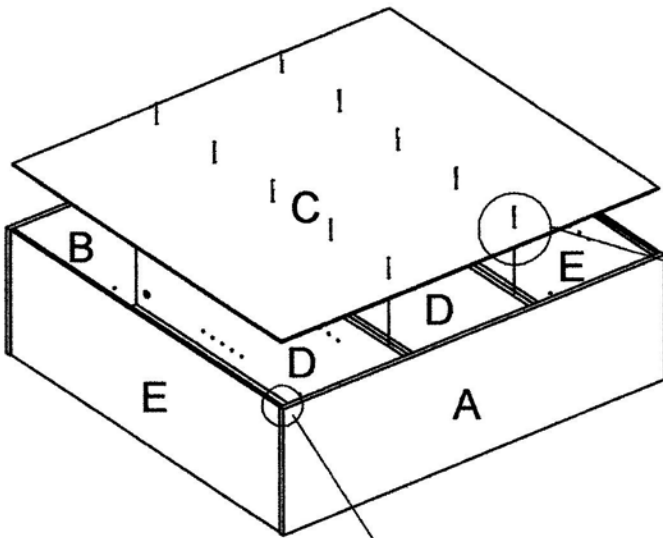

5

Note: Lay the shelves, 3 on one end and 3 on the other end, in a way that the shelves only rest on the Back Panel (C), and not on the frame of the unit. This will apply pressure on Back Panel (C) to hold it down until the glue sets for 20 to 30 minutes.

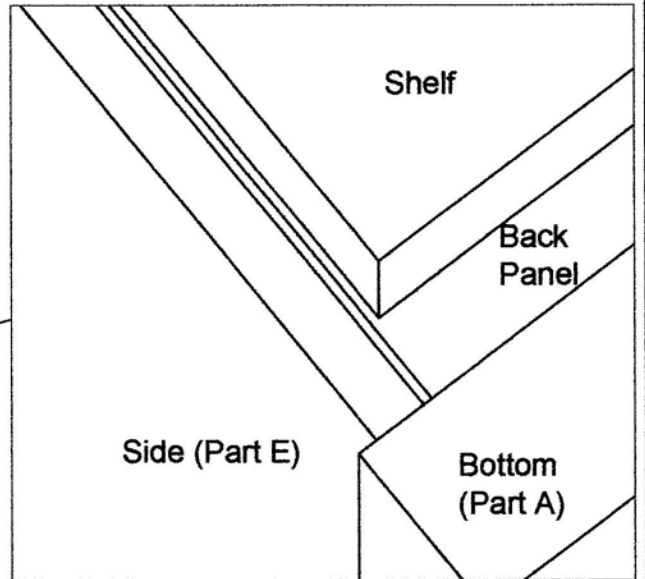
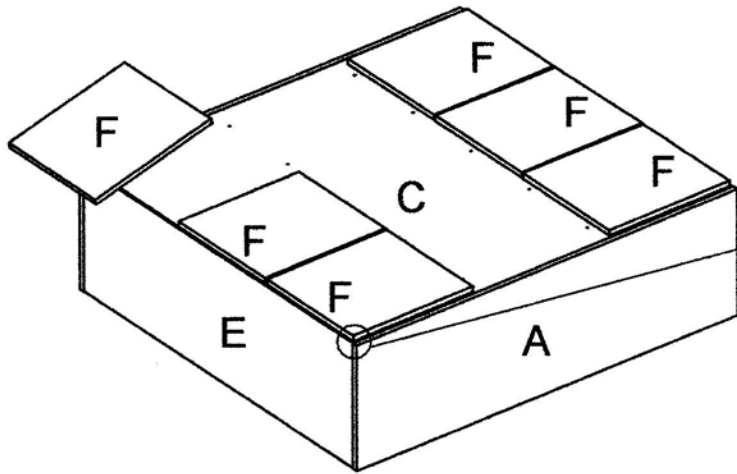

Note: Erect the unit and place the shelf supports and the shelves at the desired height.

